

20 30 40 50

# GPS Basics

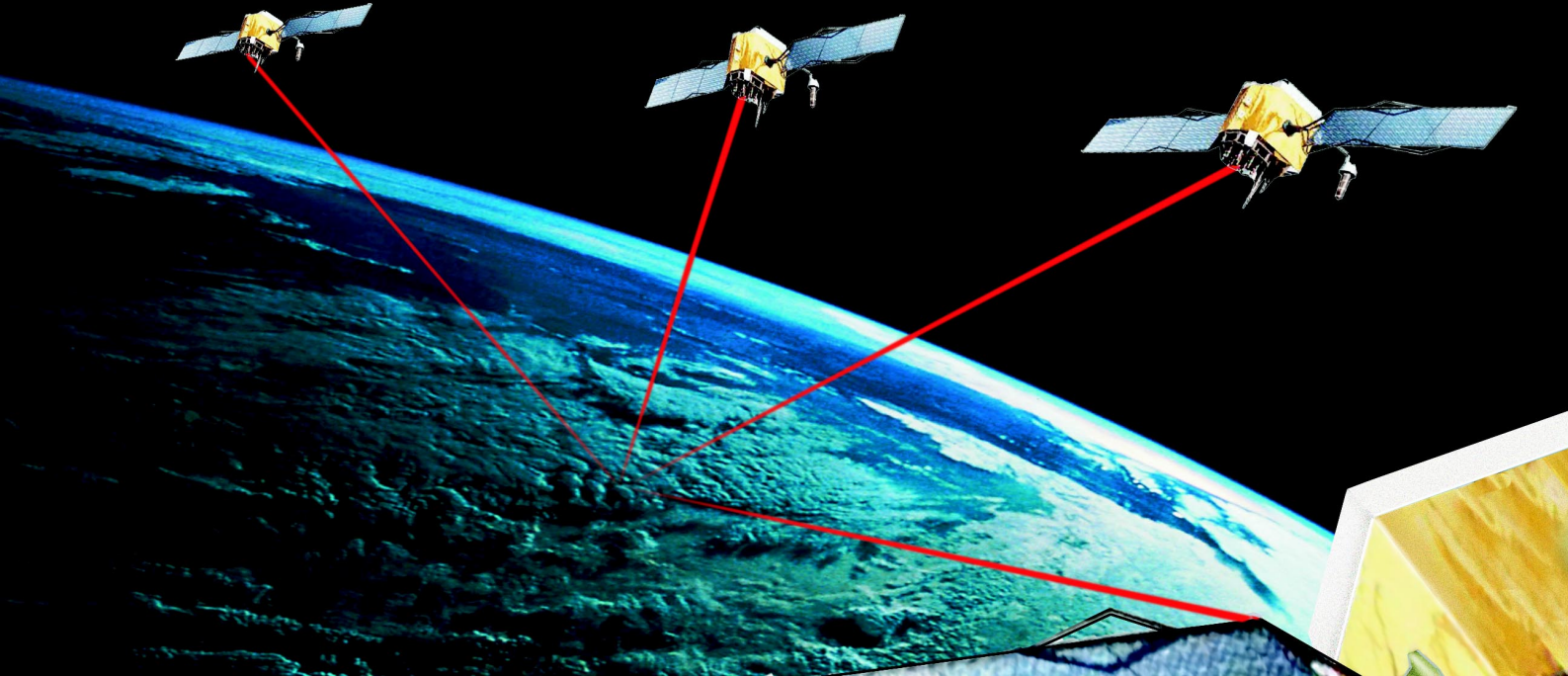

## *Introduction to GPS (Global Positioning System)*

*Version 1.0*  
*English*

*Leica*

MADE TO MEASURE

## Contents

---

<b>Preface</b> .....	<b>4</b>	<b>4. Geodetic Aspects</b> .....	<b>26</b>
<b>1. What is GPS and what does it do ?</b> .....	<b>5</b>	4.1 Introduction .....	27
<b>2. System Overview</b> .....	<b>6</b>	4.2. The GPS coordinate system .....	28
2.1 The Space Segment .....	6	4.3 Local coordinate systems .....	29
2.2 The Control Segment .....	8	4.4 Problems with height .....	30
2.3 The User Segment .....	9	4.5 Transformations .....	31
<b>3. How GPS works</b> .....	<b>10</b>	4.6 Map Projections and Plane Coordinates .....	34
3.1 Simple Navigation .....	11	4.6.1 The Transverse Mercator Projection .....	35
3.1.1 Satellite ranging .....	11	4.6.2 The Lambert Projection .....	37
3.1.2 Calculating the distance to the satellite .....	13	<b>5. Surveying with GPS</b> .....	<b>38</b>
3.1.3 Error Sources .....	14	5.1 GPS Measuring Techniques .....	39
3.1.4 Why are military receivers more accurate ? .....	18	5.1.1 Static Surveys .....	40
3.2 Differentially corrected positions (DGPS) .....	19	5.1.2 Rapid Static Surveys .....	42
3.2.1 The Reference Receiver .....	20	5.1.3 Kinematic Surveys .....	44
3.2.2 The Rover receiver .....	20	5.1.4 RTK Surveys .....	45
3.2.3 Further details .....	20	5.2 Pre-survey preparation .....	46
3.3 Differential Phase GPS and Ambiguity Resolution ...	22	5.3 Tips during operation .....	46
3.3.1 The Carrier Phase, C/A and P-codes .....	22	<b>Glossary</b> .....	<b>48</b>
3.3.2 Why use Carrier Phase? .....	23	<b>Further Reading</b> .....	<b>59</b>
3.3.3 Double Differencing .....	23	<b>Index</b> .....	<b>60</b>
3.3.4 Ambiguity and Ambiguity Resolution .....	24		

**Preface**

**4**

**1. What is GPS and what does it do?**

**5**

**2. System Overview**

**6**

**3. How GPS works**

**10**

**4. Geodetic Aspects**

**26**

**5. Surveying with GPS**

**38**

**Glossary**

**48**

**Index**

**60**

## ***Preface***

### **Why have we written this book and who should read it?**

Leica manufactures, amongst other things, GPS hardware and software. This hardware and software is used by many professionals in many applications. One thing that almost all of our users have in common is that they are not GPS scientists or experts in Geodesy. They are using GPS as a tool to complete a task. Therefore, it is useful to have background information about what GPS is and how it works.

This book is intended to give a novice or potential GPS user a background in the subject of GPS and Geodesy. It is not a definitive technical GPS or Geodesy manual. There are many texts of this sort available, some of which are included in the reading list on the back pages.

This book is split into two main sections. The first explains GPS and how it works. The second explains the fundamentals of geodesy.

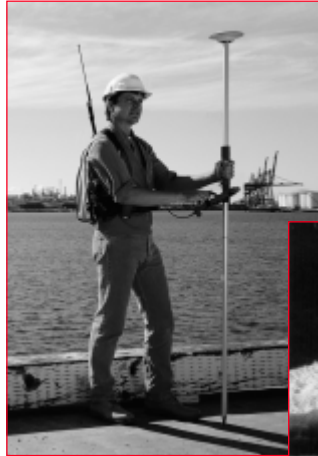

# 1. What is GPS and what does it do ?

GPS is the shortened form of NAVSTAR GPS. This is an acronym for **NAV**igation **S**ystem with **T**ime **A**nd **R**anging **G**lobal **P**ositioning **S**ystem.

GPS is a solution for one of man's longest and most troublesome problems. It provides an answer to the question 'Where on earth am I ?'



One can imagine that this is an easy question to answer. You can easily locate yourself by looking at objects that surround you and position yourself relative to them. But what if you have no objects around you ? What if you are in the middle of the desert or in the middle of the ocean ? For many centuries, this problem was solved by using the sun

and stars to navigate. Also, on land, surveyors and explorers used familiar reference points from which to base their measurements or find their way.

These methods worked well within certain boundaries. Sun and stars cannot be seen when it is cloudy. Also, even with the most precise measurements position cannot be determined very accurately.

After the second world war, it became apparent to the U.S. Department of Defense that a solution had to be found to the problem of accurate, absolute positioning. Several projects and experiments ran during the next 25 years or so, including Transit, Timation, Loran, Decca etc. All of these projects allowed positions to be determined but were limited in accuracy or functionality.

At the beginning of the 1970s, a new project was proposed – GPS. This concept promised to fulfill all the requirements of the US government, namely that one should be able to determine ones position accurately, at any point on the earth's surface, at any time, in any weather conditions.

GPS is a satellite-based system that uses a constellation of 24 satellites to give a user an accurate position. It is important at this point to define 'accurate'. To a hiker or soldier in the desert, accurate means about 15m. To a ship in coastal waters, accurate means 5m. To a land surveyor, accurate means 1cm or less. GPS can be used to achieve all of these accuracies in all of these applications, the difference being the type of GPS receiver used and the technique employed.

GPS was originally designed for military use at any time anywhere on the surface of the earth. Soon after the original proposals were made, it became clear that civilians could also use GPS, and not only for personal positioning (as was intended for the military). The first two major civilian applications to emerge were marine navigation and surveying. Nowadays applications range from in-car navigation through truck fleet management to automation of construction machinery.

## 2. System Overview

The total GPS configuration is comprised of three distinct segments:

- The Space Segment – Satellites orbiting the earth.
- The Control Segment – Stations positioned on the earth's equator to control the satellites
- The User Segment – Anybody that receives and uses the GPS signal.

### 2.1 The Space Segment

The Space Segment is designed to consist of 24 satellites orbiting the earth at approximately 20200km every 12 hours. At time of writing there are 26 operational satellites orbiting the earth.

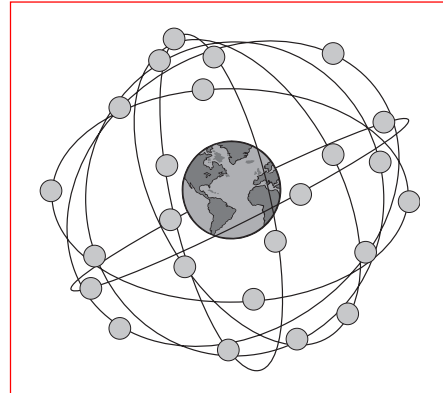

**GPS Satellite Constellation**

The space segment is so designed that there will be a minimum of 4 satellites visible above a 15° cut-off angle at any point of the earth's surface at any one time. Four satellites are the minimum that must be visible for most applications. Experience shows that there are usually at least 5 satellites visible above

15° for most of the time and quite often there are 6 or 7 satellites visible.

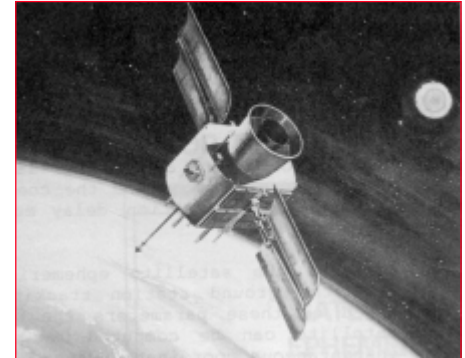

**GPS satellite**

Each GPS satellite has several very accurate atomic clocks on board. The clocks operate at a fundamental frequency of 10.23MHz. This is used to generate the signals that are broadcast from the satellite.

The satellites broadcast two carrier waves constantly. These carrier waves are in the L-Band (used for radio), and travel to earth at the speed of light. These carrier waves are derived from the fundamental frequency, generated by a very precise atomic clock:

- The L1 carrier is broadcast at 1575.42 MHz (10.23 x 154)
- The L2 carrier is broadcast at 1227.60 MHz (10.23 x 120).

The L1 carrier then has two codes modulated upon it. The C/A Code or Coarse/Acquisition Code is modulated at 1.023MHz (10.23/10) and the P-code or Precision Code is modulated at 10.23MHz). The L2 carrier has just one code modulated upon it. The L2 P-code is modulated at 10.23 MHz.

GPS receivers use the different codes to distinguish between satellites. The codes can also be used as a basis for making pseudorange measurements and therefore calculate a position.

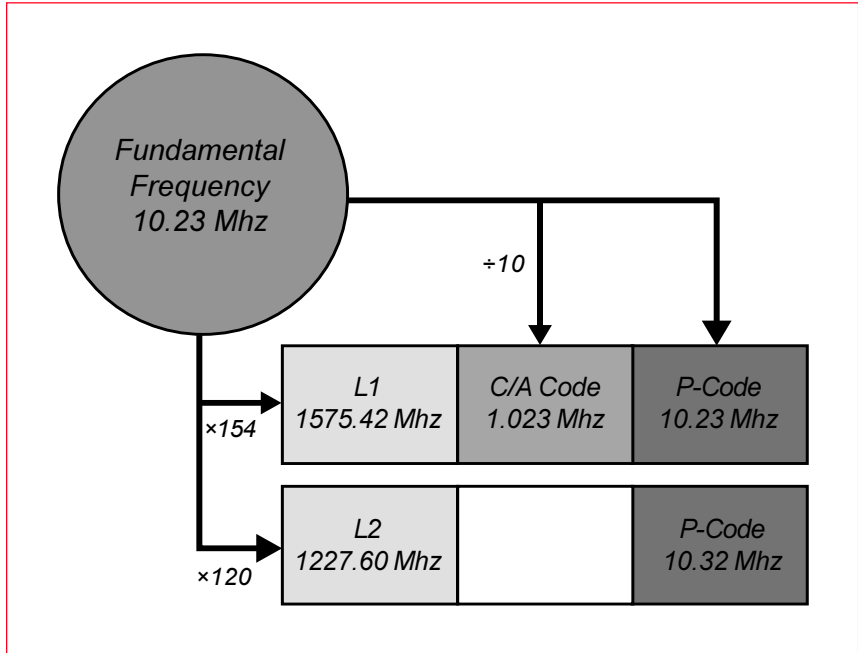

GPS Signal Structure

## 2.2 The Control Segment

The Control Segment consists of one master control station, 5 monitor stations and 4 ground antennas distributed amongst 5 locations roughly on the earth's equator.

The Control Segment tracks the GPS satellites, updates their orbiting position and calibrates and synchronises their clocks.

A further important function is to determine the orbit of each satellite and predict its path for the following 24 hours. This information is uploaded to each satellite and subsequently broadcast from it. This enables the GPS receiver to know where each satellite can be expected to be found.

The satellite signals are read at Ascension, Diego Garcia and Kwajalein. The measurements are then sent to the Master Control Station in Colorado Springs where they are processed to determine any errors in each satellite. The information is then sent back to the four monitor stations equipped with ground antennas and uploaded to the satellites.

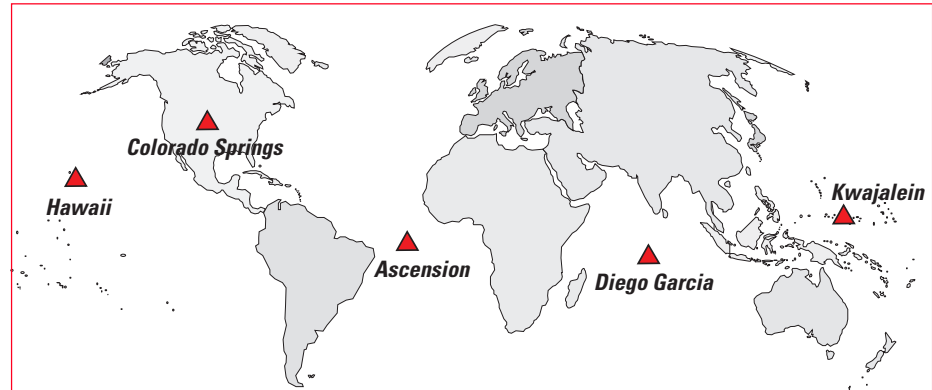

**Control Segment Station Locations**



## 2.3 The User Segment

The User Segment comprises of anyone using a GPS receiver to receive the GPS signal and determine their position and/or time. Typical applications within the user segment are land navigation for hikers, vehicle location, surveying, marine navigation, aerial navigation, machine control etc.



### 3. How GPS works

There are several different methods for obtaining a position using GPS. The method used depends on the accuracy required by the user and the type of GPS receiver available. Broadly speaking, the techniques can be broken down into three basic classes:

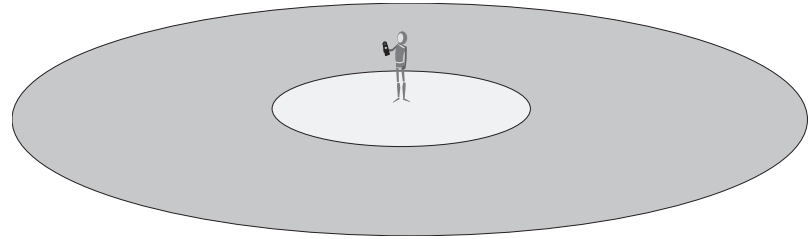

**Autonomous Navigation** using a single stand-alone receiver. Used by hikers, ships that are far out at sea and the military. Position Accuracy is better than 100m for civilian users and about 20m for military users.

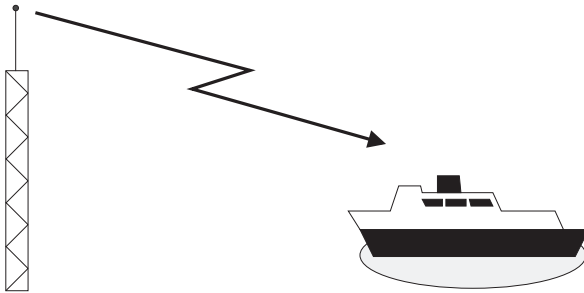

**Differentially corrected positioning.** More commonly known as DGPS, this gives an accuracy of between 0.5-5m. Used for inshore marine navigation, GIS data acquisition, precision farming etc.

**Differential Phase position.** Gives an accuracy of 0.5-20mm. Used for many surveying tasks, machine control etc.

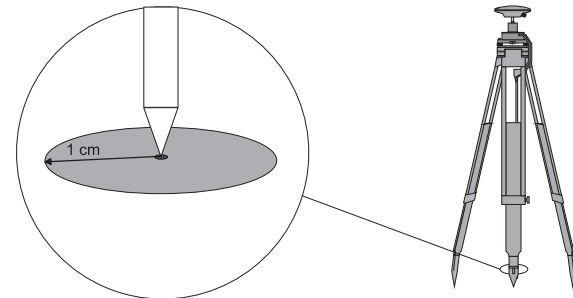

## 3.1 Simple Navigation

This is the most simple technique employed by GPS receivers to instantaneously give a position and height and/or accurate time to a user. The accuracy obtained is better than 100m (usually around the 30-50m mark) for civilian users and 5-15m for military users. The reasons for the difference between civilian and military accuracies are given later in this section. Receivers used for this type of operation are typically small, highly portable handheld units with a low cost.



*A Handheld GPS Receiver*

### 3.1.1 Satellite ranging

All GPS positions are based on measuring the distance from the satellites to the GPS receiver on the earth. This distance to each satellite can be determined by the GPS receiver. The basic idea is that of resection, which many surveyors use in their daily work. If you know the distance to three points relative to your own position, you can determine your own position relative to those three points. From the distance to one satellite we know that the position of the receiver must be at some point on the surface of an imaginary sphere which has its origin at the satellite. By intersecting three imaginary spheres the receiver position can be determined.

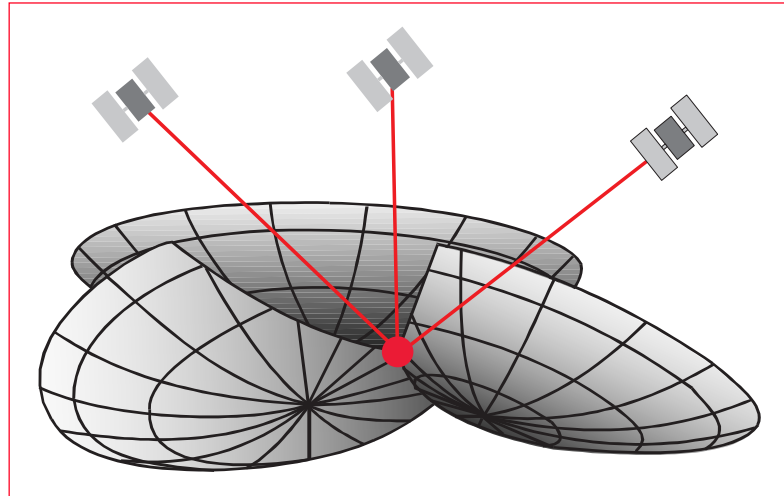

*Intersection of three imaginary spheres*

The problem with GPS is that only pseudoranges and the time at which the signal arrived at the receiver can be determined.

Thus there are four unknowns to determine; position (X, Y, Z) and time of travel of the signal. Observing to four satellites produces four equations which can be solved, enabling these unknowns to be determined.

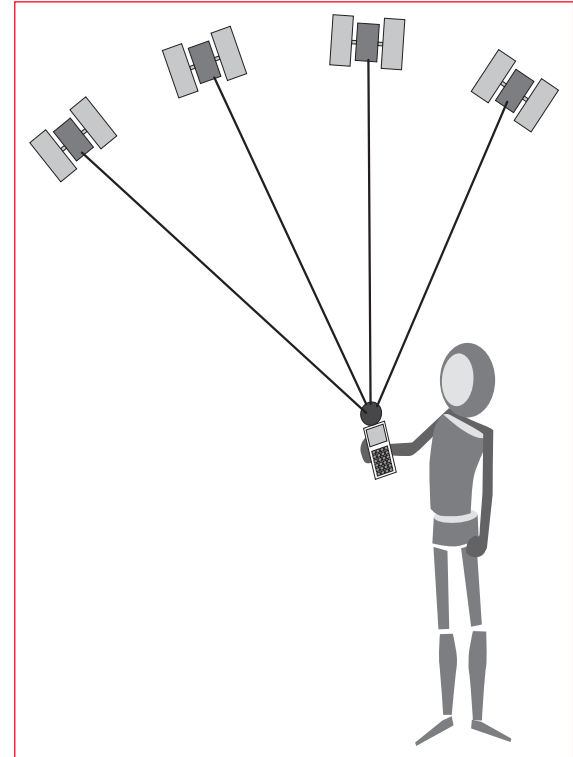

***At least four satellites are required to obtain a position and time in 3 dimensions***

### 3.1.2 Calculating the distance to the satellite

In order to calculate the distance to each satellite, one of Isaac Newton's laws of motion is used:

$$\text{Distance} = \text{Velocity} \times \text{Time}$$

For instance, it is possible to calculate the distance a train has traveled if you know the velocity it has been travelling and the time for which it has been travelling at that velocity.

GPS requires the receiver to calculate the distance from the receiver to the satellite.

The Velocity is the velocity of the radio signal. Radio waves travel at the speed of light, 290,000 km per second (186,000 miles per second).

The Time is the time taken for the radio signal to travel from the satellite to the GPS receiver. This is a little harder to calculate, since you need to know when the radio signal left the satellite and when it reached the receiver.

#### Calculating the Time

The satellite signal has two codes modulated upon it, the C/A code and the P-code (see section 2.1). The C/A code is based upon the time given by a very accurate atomic clock. The receiver also contains a clock that is used to generate a matching C/A code. The GPS receiver is then able to "match" or correlate the incoming satellite code to the receiver generated code.

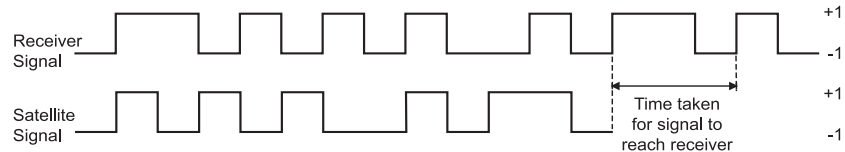

The C/A code is a digital code that is 'pseudo random' or appears to be random. In actual fact it is not random and repeats one thousand times every second.

In this way, the time taken for the radio signal to travel from the satellite to the GPS receiver is calculated.

### 3.1.3 Error Sources

Up until this point, it has been assumed that the position derived from GPS is very accurate and free of error, but there are several sources of error that degrade the GPS position from a theoretical few metres to tens of metres. These error sources are:

1. Ionospheric and atmospheric delays
2. Satellite and Receiver Clock Errors
3. Multipath
4. Dilution of Precision
5. Selective Availability (S/A)
6. Anti Spoofing (A-S)

#### 1. Ionospheric and Atmospheric delays

As the satellite signal passes through the ionosphere, it can be slowed down, the effect being similar to light refracted through a glass block. These atmospheric delays can introduce an error in the range calculation as the velocity of the signal is affected. (Light only has a constant velocity in a vacuum).

The ionosphere does not introduce a constant delay on the signal. There are several factors that influence the amount of delay caused by the ionosphere.

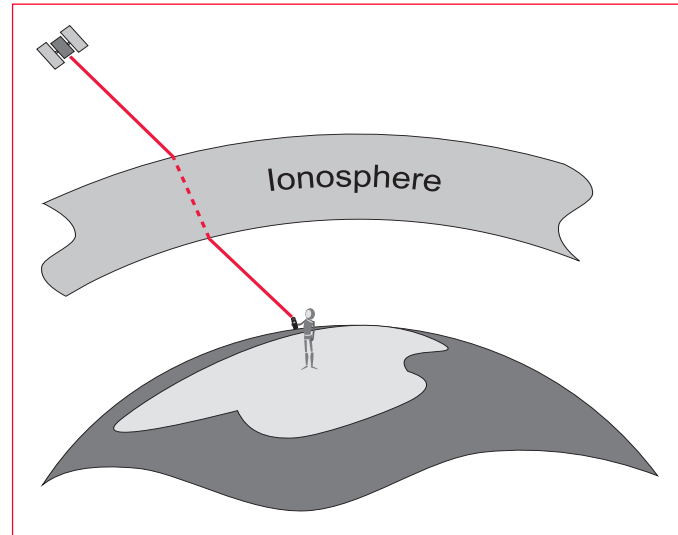

**a. Satellite elevation.** Signals from low elevation satellites will be affected more than signals from higher elevation satellites. This is due to the increased distance that the signal passes through the atmosphere.

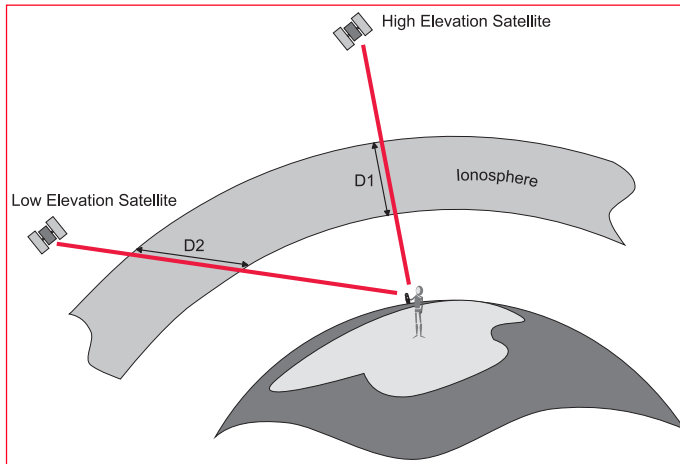

**b. The density of the ionosphere is affected by the sun.** At night, there is very little ionospheric influence. In the day, the sun increases the effect of the ionosphere and slows down the signal.

The amount by which the density of the ionosphere is increased varies with solar cycles (sunspot activity).

Sunspot activity peaks approximately every 11 years. At the time of writing, the next peak (solar max) will be around the year 2000.

In addition to this, solar flares can also randomly occur and also have an effect on the ionosphere.

Ionospheric errors can be mitigated by using one of two methods:

- The first method involves taking an average of the

effect of the reduction in velocity of light caused by the ionosphere. This correction factor can then be applied to the range calculations. However, this relies on an average and obviously this

average condition does not occur all of the time. This method is therefore not the optimum solution to Ionospheric Error mitigation.

- The second method involves using “dual-frequency” GPS receivers. Such receivers measure the L1 and the L2 frequencies of the GPS signal. It is known that when a radio signal travels through the ionosphere it slows down at a rate inversely proportional to its frequency. Hence, if the arrival times of the two signals are compared, an accurate estimation of the delay can be made. Note that this is only possible with dual frequency GPS receivers. Most receivers built for navigation are single frequency.

**c. Water Vapour also affects the GPS signal.** Water vapor contained in the atmosphere can also affect the GPS signal. This effect, which can result in a position degradation can be reduced by using atmospheric models.

## 2. Satellite and Receiver clock errors

Even though the clocks in the satellite are very accurate (to about 3 nanoseconds), they do sometimes drift slightly and cause small errors, affecting the accuracy of the position. The US Department of Defense monitors the satellite clocks using the Control Segment (see section 2.2) and can correct any drift that is found.

## 3. Multipath Errors

Multipath occurs when the receiver antenna is positioned close to a large reflecting surface such as a lake or building. The satellite signal does not travel directly to the antenna but hits the nearby object first and is reflected into the antenna creating a false measurement.

Multipath can be reduced by use of special GPS antennas that incorporate a ground plane (a circular, metallic disk about 50cm (2 feet) in diameter) that prevent low elevation signals reaching the antenna.

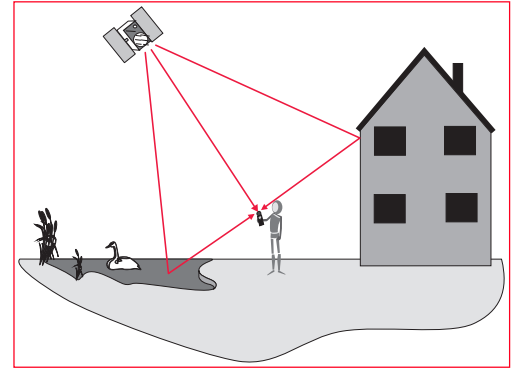

For highest accuracy, the preferred solution is use of a choke ring antenna. A choke ring antenna has 4 or 5 concentric rings around the antenna that trap any indirect signals.

Multipath only affects high accuracy, survey-type measurements. Simple handheld navigation receivers do not employ such techniques.



**Choke-Ring Antenna**



#### 4. Dilution of Precision

The Dilution of Precision (DOP) is a measure of the strength of satellite geometry and is related to the spacing and position of the satellites in the sky. The DOP can magnify the effect of satellite ranging errors.

The principle can be best illustrated by diagrams:

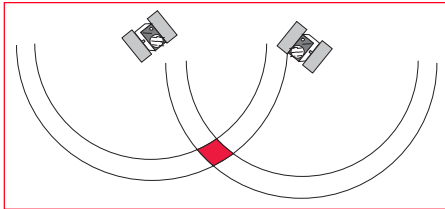

**Well spaced satellites - low uncertainty of position**

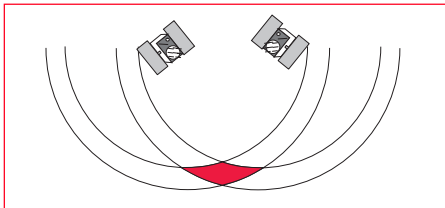

**Poorly spaced satellites - high uncertainty of position**

The range to the satellite is affected by range errors previously described. When the satellites are well spaced, the position can be determined as being within the shaded area in the diagram and the possible error margin is small.

When the satellites are close together, the shaded area increases in size, increasing the uncertainty of the position.

Different types of Dilution of Precision or DOP can be calculated depending on the dimension.

**VDOP** – Vertical Dilution of Precision.  
Gives accuracy degradation in vertical direction.

**HDOP** – Horizontal Dilution of Precision.  
Gives accuracy degradation in horizontal direction.

**PDOP** – Positional Dilution of Precision.  
Gives accuracy degradation in 3D position.

**GDOP** – Geometric Dilution of Precision.  
Gives accuracy degradation in 3D position and time.

The most useful DOP to know is GDOP since this is a combination of all the factors. Some receivers do however calculate PDOP or HDOP which do not include the time component.

The best way of minimizing the effect of GDOP is to observe as many satellites as possible. Remember however, that the signals from low elevation satellites are generally influenced to a greater degree by most error sources.

As a general guide, when surveying with GPS it is best to observe satellites that are  $15^\circ$  above the horizon. The most accurate positions will generally be computed when the GDOP is low, (usually 8 or less).

### **3.1.4 Why are military receivers more accurate ?**

#### **5. Selective Availability (S/A)**

Selective Availability is a process applied by the U.S. Department of Defense to the GPS signal. This is intended to deny civilian and hostile foreign powers the full accuracy of GPS by subjecting the satellite clocks to a process known as 'dithering' which alters their time slightly. Additionally, the ephemeris (or path that the satellite will follow) is broadcast as being slightly different from what it is in reality. The end result is a degradation in position accuracy.

It is worth noting that S/A affects civilian users using a single GPS receiver to obtain an autonomous position. Users of differential systems are not significantly affected by S/A.

Currently, it is planned that S/A will be switched off by 2006 at the latest.

#### **6. Anti-Spoofing (A-S)**

Anti-Spoofing is similar to S/A in that its intention is to deny civilian and hostile powers access to the P-code part of the GPS signal and hence force use of the C/A code which has S/A applied to it.

Anti-Spoofing encrypts the P-code into a signal called the Y-code. Only users with military GPS receivers (the US and its allies) can de-encrypt the Y-code.



*A military handheld GPS receiver  
(courtesy Rockwell)*

Military receivers are more accurate because they do not use the C/A code to calculate the time taken for the signal to reach the receiver. They use the P-code.

The P-code is modulated onto the carrier wave at 10.23 Hz. The C/A code is modulated onto the carrier wave at 1.023 Hz. Ranges can be calculated far more accurately using the P-code as this code is occurring 10 times as often as the C/A code per second.

The P-code is often subjected to Anti Spoofing (A/S) as described in the last section. This means that only the military, equipped with special GPS receivers can read this encrypted P-code (also known as the Y-code).

For these reasons, users of military GPS receivers usually get a position with an accuracy of around 5m whereas, civilian users of comparable GPS receivers will only get between about 15-100m position accuracy.

## 3.2 Differentially corrected positions (DGPS)

Many of the errors affecting the measurement of satellite range can be completely eliminated or at least significantly reduced using differential measurement techniques.

DGPS allows the civilian user to increase position accuracy from 100m to 2-3m or less, making it more useful for many civilian applications.

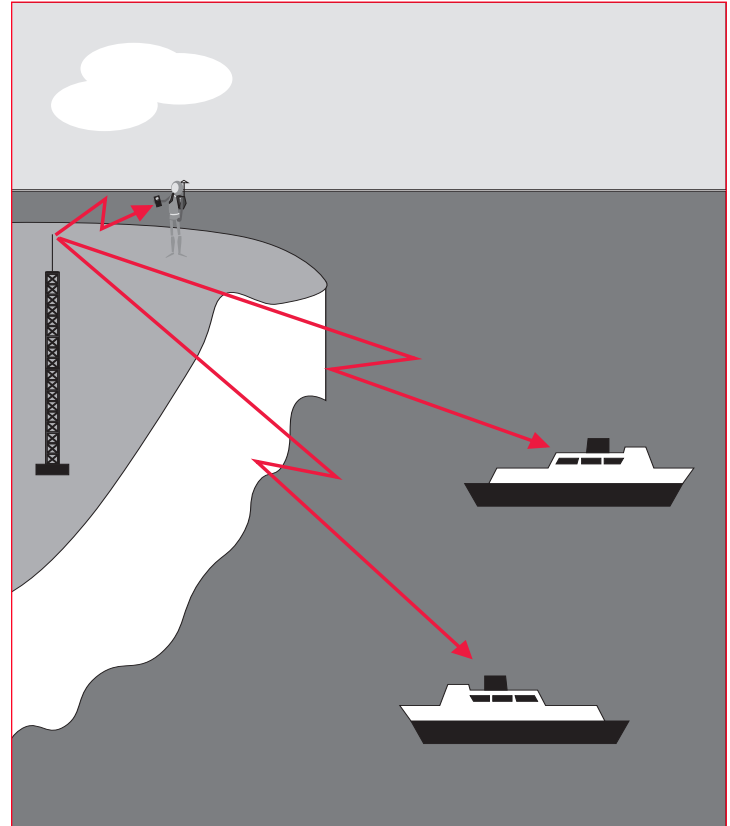

DGPS Reference station broadcasting to Users

### 3.2.1 The Reference Receiver

The Reference receiver antenna is mounted on a previously measured point with known coordinates. The receiver that is set at this point is known as the Reference Receiver or Base Station.

The receiver is switched on and begins to track satellites. It can calculate an autonomous position using the techniques mentioned in section 3.1.

Because it is on a known point, the reference receiver can estimate very precisely what the ranges to the various satellites should be.

The reference receiver can therefore work out the difference between the computed and measured range values. These differences are known as corrections.

The reference receiver is usually attached to a radio data link which is used to broadcast these corrections.

### 3.2.2 The Rover receiver

The rover receiver is on the other end of these corrections. The rover receiver has a radio data link attached to it that enables it to receive the range corrections broadcast by the Reference Receiver.

The Rover Receiver also calculates ranges to the satellites as described in section 3.1. It then applies the range corrections received from the Reference. This lets it calculate a much more accurate position than would be possible if the uncorrected range measurements were used.

Using this technique, all of the error sources listed in section 3.1.3 are minimized, hence the more accurate position.

It is also worthwhile to note that multiple Rover Receivers can receive corrections from one single Reference.

### 3.2.3 Further details

DGPS has been explained in a very simple way in the preceding sections. In real life, it is a little more complex than this.

One large consideration is the radio link. There are many types of radio link that will broadcast over different ranges and frequencies. The performance of the radio link depends on a range of factors including:

- Frequency of the radio
- Power of the radio
- Type and 'gain' of radio antenna
- Antenna position

Networks of GPS receivers and powerful radio transmitters have been established, broadcasting on a "maritime only" safety frequency. These are known as Beacon Transmitters. The users of this service (mostly marine craft navigating in coastal waters) just need to purchase a Rover receiver that can receive the beacon signal. Such systems have been set up around the coasts of many countries.

---

Other devices such as mobile tele-  
phones can also be used for transmis-  
sion of data.

In addition to Beacon Systems, other  
systems also exist that provide coverage  
over large land areas operated by  
commercial, privately owned companies.  
There are also proposals for govern-  
ment owned systems such as the  
Federal Aviation Authority's satellite-  
based Wide Area Augmentation System  
(WAAS) in the United States, the Euro-  
pean Space Agency's (ESA) system and  
a proposed system from the Japanese  
government.

There is a commonly used standard for  
the format of broadcast GPS data. It is  
called RTCM format. This stands for  
Radio Technical Commission Maritime  
Services, an industry sponsored non-  
profit organisation. This format is  
commonly used all over the world.

## 3.3 Differential Phase GPS and Ambiguity Resolution

Differential Phase GPS is used mainly in surveying and related industries to achieve relative positioning accuracies of typically 5-50mm (0.25-2.5 in). The technique used differs from previously described techniques and involves a lot of statistical analysis.

It is a differential technique which means that a minimum of two GPS receivers are always used simultaneously. This is one of the similarities with the Differential Code Correction method described in section 3.2.

The Reference Receiver is always positioned at a point with fixed or known coordinates. The other receiver(s) are free to rove around. Thus they are known as Rover Receivers. The baseline(s) between the Reference and Rover receiver(s) are calculated.

The basic technique is still the same as with the techniques mentioned previously, - measuring distances to four satellites and computing a position from those ranges.

The big difference comes in the way those ranges are calculated.

### 3.3.1 The Carrier Phase, C/A and P-codes

At this point, it is useful to define the various components of the GPS signal.

**Carrier Phase.** The sine wave of the L1 or L2 signal that is created by the satellite. The L1 carrier is generated at 1575.42MHz, the L2 carrier at 1227.6 MHz.

**C/A code.** The Coarse Acquisition code. Modulated on the L1 Carrier at 1.023MHz.

**P-code.** The precise code. Modulated on the L1 and L2 carriers at 10.23 MHz.

Refer also to the diagram in section 2.1.

#### What does modulation mean ?

The carrier waves are designed to carry the binary C/A and P-codes in a process known as modulation. Modulation means the codes are superimposed on the carrier wave. The codes are binary codes. This means they can only have the values 1 or -1. Each time the value changes, there is a change in the phase of the carrier.

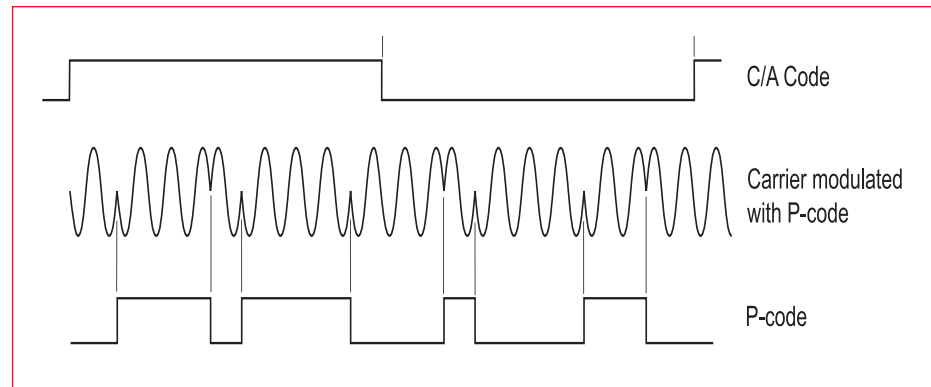

Carrier Modulation

### 3.3.2 Why use Carrier Phase?

The carrier phase is used because it can provide a much more accurate measurement to the satellite than using the P-code or the C/A code. The L1 carrier wave has a wavelength of 19.4 cm. If you could measure the number of wavelengths (whole and fractional parts) there are between the satellite and receiver, you have a very accurate range to the satellite.

### 3.3.3 Double Differencing

The majority of the error incurred when making an autonomous position comes from imperfections in the receiver and satellite clocks. One way of bypassing this error is to use a technique known as Double Differencing.

If two GPS receivers make a measurement to two different satellites, the clock offsets in the receivers and satellites cancel, removing any source of error that they may contribute to the equation.

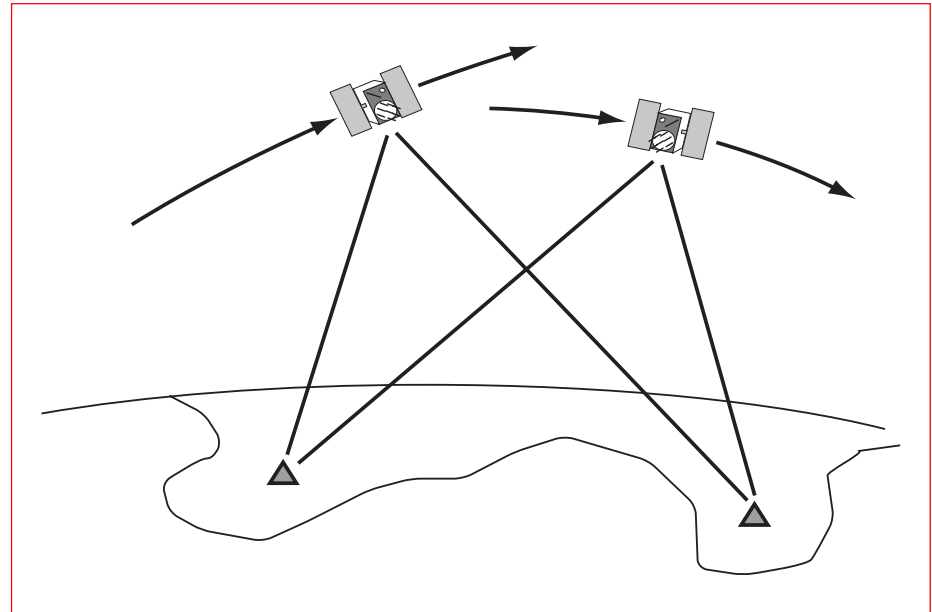

Double Differencing

### 3.3.4 Ambiguity and Ambiguity Resolution

After removing the clock errors by double differencing, the whole number of carrier wavelengths plus a fraction of a wavelength between the satellite and receiver antenna can be determined. The problem is that there are many 'sets' of possible whole wavelengths to each observed satellite. Thus the solution is ambiguous. Statistical processes can resolve this ambiguity and determine the most probable solution.

The following explanation is an outline of how the ambiguity resolution process works. Many complicating factors are not covered by this explanation but it does provide a useful illustration.

Differential code can be used to obtain

1.

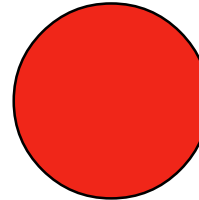

an approximate position. The precise answer must lie somewhere within this circle.

The wavefronts from a single satellite

2.

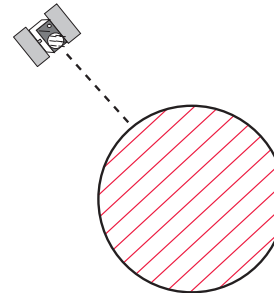

strike both within and outside of the circle. The precise point must lie somewhere on one of the lines formed by these wavefronts inside the circle.

**Continued...**

When a second satellite is observed,



**3.**

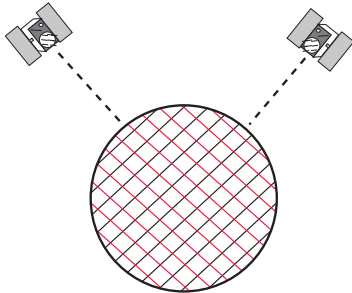

a second set of wavefronts or phase lines are created. The point must lie on one of the intersections of the two sets of phase lines.

Adding a third

**5.**

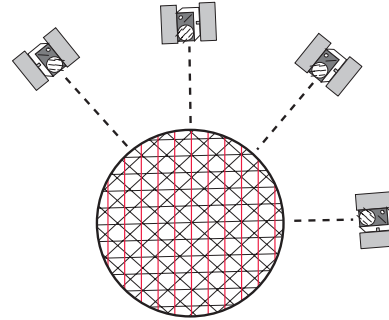

satellite further narrows the number of possibilities.

As the satellite

**4.**

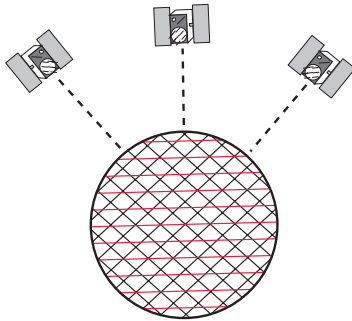

satellite further narrows the number of possibilities. The point must be on an intersection of all three phase lines.

Adding a fourth

**6.**

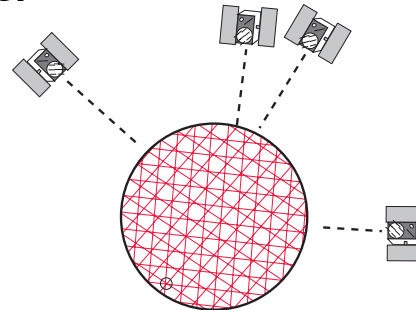

constellation changes it will tend to rotate around one point, revealing the most probable solution.

## 4. Geodetic Aspects

Since GPS has become increasingly popular as a Surveying and Navigation instrument, surveyors and navigators require a basic understanding of how GPS positions relate to standard mapping systems.

A common cause of errors in GPS surveys is the result of incorrectly understanding these relationships.

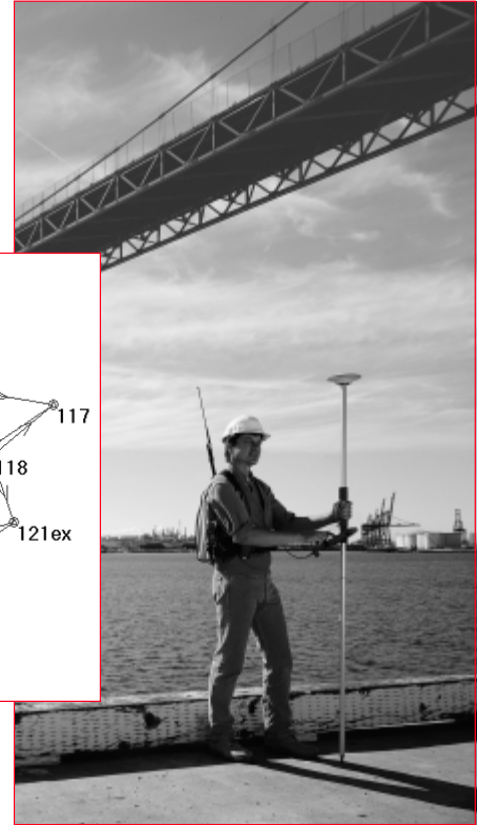
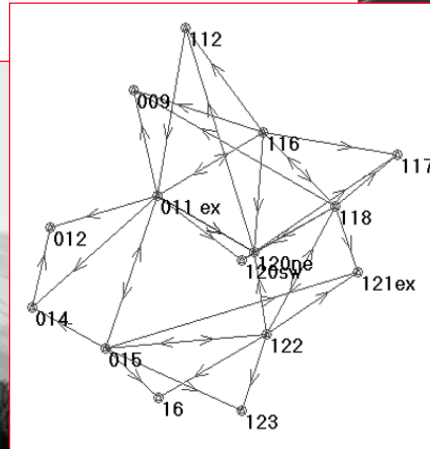

## 4.1 Introduction

Determining a position with GPS achieves a fundamental goal of Geodesy - the determination of absolute position with uniform accuracy at all points on the earth's surface. Using classical geodetic and surveying techniques, determination of position is always relative to the starting points of the survey, with the accuracy achieved being dependent on the distance from this point. GPS therefore, offers a significant advantage over conventional techniques.

The science of Geodesy is basic to GPS, and, conversely, GPS has become a major tool in Geodesy. This is evident if we look at the aims of Geodesy:

1. Establishment and maintenance of national and global three-dimensional geodetic control networks on land, recognizing the time-varying nature of these networks due to plate movement.
2. Measurement and representation of geodynamic phenomena (polar motion, earth tides, and crustal motion).
3. Determination of the gravity field of the earth including temporal variations.

Although most users may never carry out any of the above tasks, it is essential that users of GPS equipment have a general understanding of Geodesy.

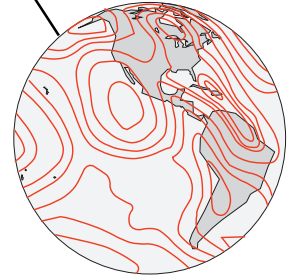
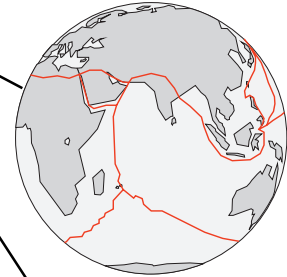

## 4.2. The GPS coordinate system

Although the earth may appear to be a uniform sphere when viewed from space, the surface is far from uniform. Due to the fact that GPS has to give coordinates at any point on the earth's surface, it uses a geodetic coordinate system based on an ellipsoid. An ellipsoid (also known as a spheroid) is a sphere that has been flattened or squashed.

An ellipsoid is chosen that most accurately approximates to the shape of the earth. This ellipsoid has no physical surface but is a mathematically defined surface.

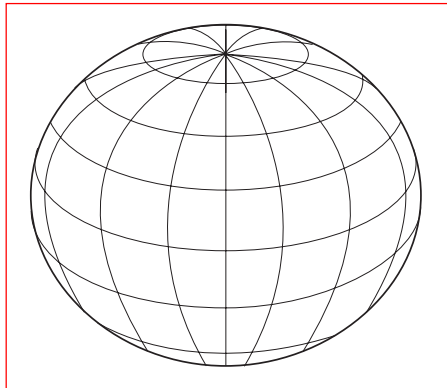

An Ellipsoid

There are actually many different ellipsoids or mathematical definitions of the earth's surface, as will be discussed later. The ellipsoid used by GPS is known as WGS84 or World Geodetic System 1984.

A point on the surface of the earth (note that this is not the surface of the ellipsoid), can be defined by using Latitude, Longitude and ellipsoidal height.

An alternative method for defining the position of a point is the Cartesian Coordinate system, using distances in the X, Y, and Z axes from the origin or centre of the spheroid. This is the method primarily used by GPS for defining the location of a point in space.

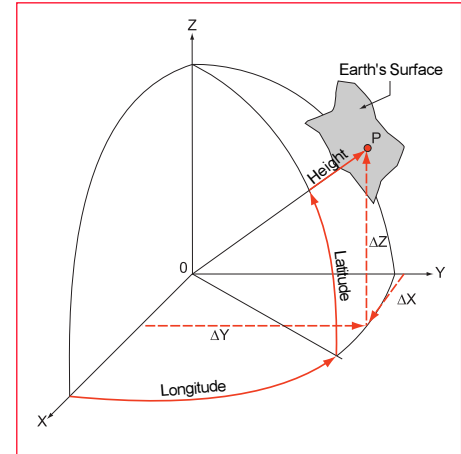

Defining coordinates of P by Geodetic and Cartesian coordinates

## 4.3 Local coordinate systems

Just as with GPS coordinates, local coordinates or coordinates used in a particular country's maps are based on a local ellipsoid, designed to match the geoid (see section 4.4) in the area. Usually, these coordinates will have been projected onto a plane surface to provide grid coordinates (see section 4.5).

The ellipsoids used in most local coordinate systems throughout the world were first defined many years ago, before the advent of space techniques. These ellipsoids tend to fit the area of interest well but could not be applied to other areas of the earth. Hence, each country defined a mapping system/ reference frame based on a local ellipsoid.

When using GPS, the coordinates of the calculated positions are based on the WGS84 ellipsoid. Existing coordinates are usually in a local coordinate system and therefore the GPS coordinates have to be transformed into this local system.

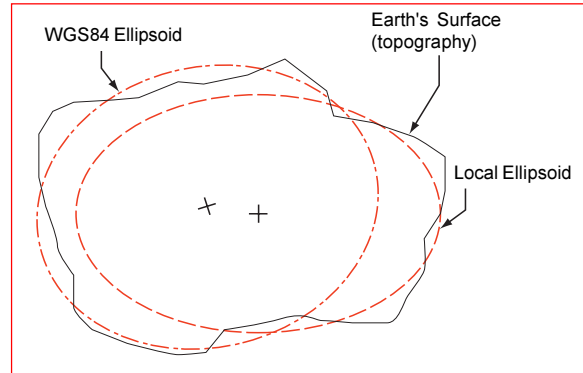

***The relationship between ellipsoids and the earth's surface***

## 4.4 Problems with height

The nature of GPS also affects the measurement of height.

All heights measured with GPS are given in relation to the surface of the WGS84 ellipsoid. These are known as Ellipsoidal Heights.

Existing heights are usually orthometric heights measured relative to mean sea level.

Mean sea level corresponds to a surface known as the geoid. The Geoid can be defined as an equipotential surface, i.e. the force of gravity is a constant at any point on the geoid.

The geoid is of irregular shape and does not correspond to any ellipsoid. The density of the earth does however have an effect on the geoid, causing it to rise in the more dense regions and fall in less dense regions.

The relationship between the geoid, ellipsoid and earth's surface is shown in the graphic below.

As most existing maps show orthometric heights (relative to the geoid), most users of GPS also require their heights to be orthometric.

This problem is solved by using geoidal models to convert ellipsoidal heights to orthometric heights. In relatively flat areas the geoid can be considered to be constant. In such areas, use of certain transformation techniques can create a height model and geoidal heights can be interpolated from existing data.

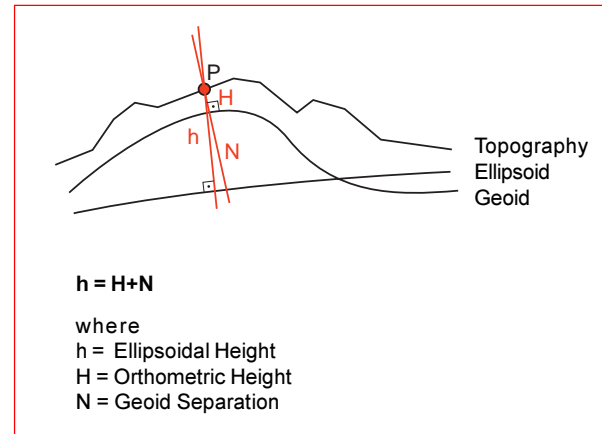

**Relationship between Orthometric and Ellipsoidal height**

## 4.5 Transformations

The purpose of a transformation is to transform coordinates from one system to another.

Several different Transformation approaches exist. The one that you use will depend on the results you require.

The basic field procedure for determination of transformation parameters is the same no matter which approach is taken.

Firstly, coordinates must be available in both coordinate systems (i.e. in WGS84 and in the local system) for at least three (and preferably four) common points. The more common points you include in the transformation, the more opportunity you have for redundancy and error checking.

Common points are achieved by measuring points with GPS, where the coordinates and orthometric heights are known in the local system, (e.g. existing control points).

The transformation parameters can then be calculated using one of the transformation approaches.

It is important to note that the transformation will only apply to points in the area bounded by the common points. Points outside of this area should not be transformed using the calculated parameters but should form part of a new transformation area.

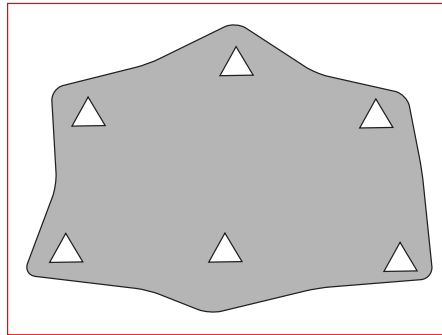

***Transformations apply within an area of common points***

## Helmert Transformations

The Helmert 7 parameter transformation offers a mathematically correct transformation. This maintains the accuracy of the GPS measurements and local coordinates.

Experience has shown that it is common for GPS surveys to be measured to a much higher accuracy than older surveys measured with traditional optical instruments.

In the vast majority of cases, the previously measured points will not be as accurate as the new points measured with GPS. This may create non-homogeneity in the network.

When transforming a point between coordinate systems, it is best to think of the origin from which the coordinates are derived as changing and not the surface on which it lies.

In order to transform a coordinate from one system to another, the origins and axes of the ellipsoid must be known relative to each other. From this information, the shift in space in X, Y and Z from one origin to the other can be deter-

mined, followed by any rotation about the X, Y and Z axes and any change in scale between the two ellipsoids.

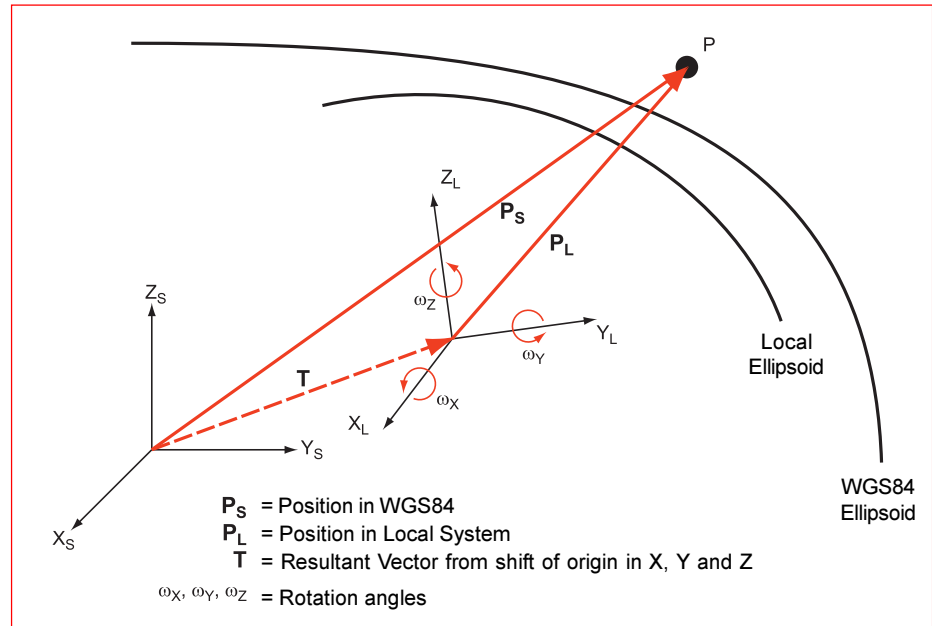

**7 parameter Helmert transformation**



## Other transformation approaches

Whilst the Helmert transformation approach is mathematically correct, it cannot account for irregularities in the local coordinate system and for accurate heighting, the geoid separation must be known.

Therefore, Leica also makes a number of other transformation approaches available in its equipment and software.

The so-called **Interpolation approach** does not rely on knowledge of the local ellipsoid or map projection.

Inconsistencies in the local coordinates are dealt with by stretching or squeezing any GPS coordinates to fit homogeneously in the local system.

Additionally a height model can be constructed. This compensates for lack of geoid separations, provided sufficient control points are available.

As an alternative to the Interpolation approach the **One Step approach** may be used. This transformation approach also works by treating the height and position transformations separately. For the position transformation, the WGS84

coordinates are projected onto a temporary Transverse Mercator projection and then the shifts, rotation and scale from the temporary projection to the "real" projection are calculated. The Height transformation is a single dimension height approximation.

This transformation may be used in areas where the local ellipsoid and map projection are unknown and where the geoid is reasonably constant.

Both the Interpolation and the One Step approach should be limited to an area of about 15 x 15km, (10 x 10 miles).

A combination of the Helmert and Interpolation approaches may be found in the **Stepwise approach**. This approach uses a 2D Helmert transformation to obtain position and a height interpolation to obtain heights. This approach requires the knowledge of local ellipsoid and map projection.

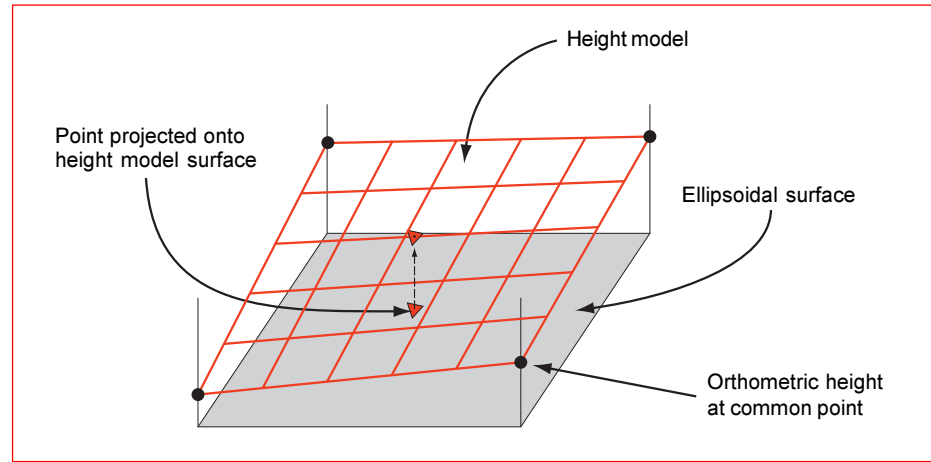

*Height model generated from 4 known points*

## 4.6 Map Projections and Plane Coordinates

Most Surveyors measure and record coordinates in an orthogonal grid system. This means that points are defined by Northings, Eastings and orthometric height (height above sea level). Map Projections allow surveyors to represent a 3 dimensional curved surface on a flat piece of paper.

Such map projections appear as planes but actually define mathematical steps for specifying positions on an ellipsoid in the terms of a plane.

The way in which a map projection generally works is shown in the diagram. Points on the surface of the

spheroid are projected on to a plane surface from the origin of the spheroid.

The diagram also highlights the problem that it is not possible to represent true lengths or shapes on such a plane. True lengths are only represented where the plane cuts the spheroid (points c and g).

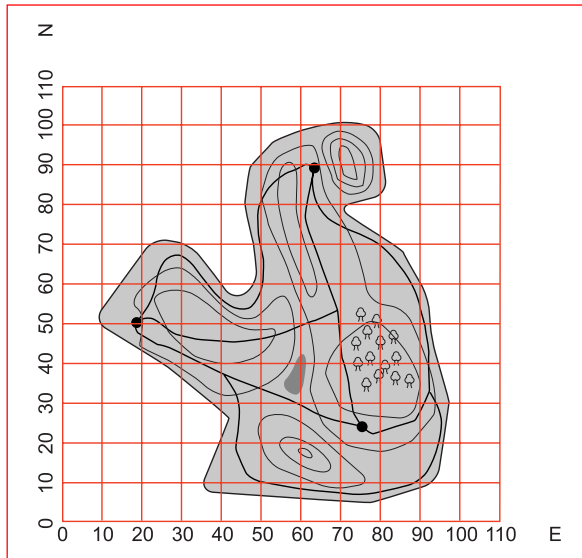

A plane grid based map

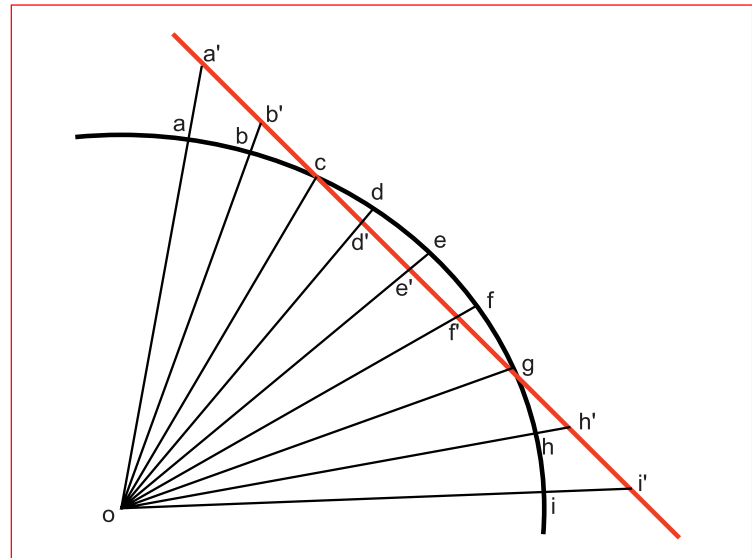

The basic idea behind map projections

## 4.6.1 The Transverse Mercator Projection

The Transverse Mercator projection is a conformal projection. This means that angular measurements made on the projection surface are true.

The Projection is based on a cylinder that is slightly smaller than the spheroid and is then flattened out. The method is used by many countries and is especially suited to large countries around the equator.

The Transverse Mercator Projection is defined by:

- False Easting and False Northing.
- Latitude of Origin
- Central Meridian
- Scale on Central meridian
- Zone Width

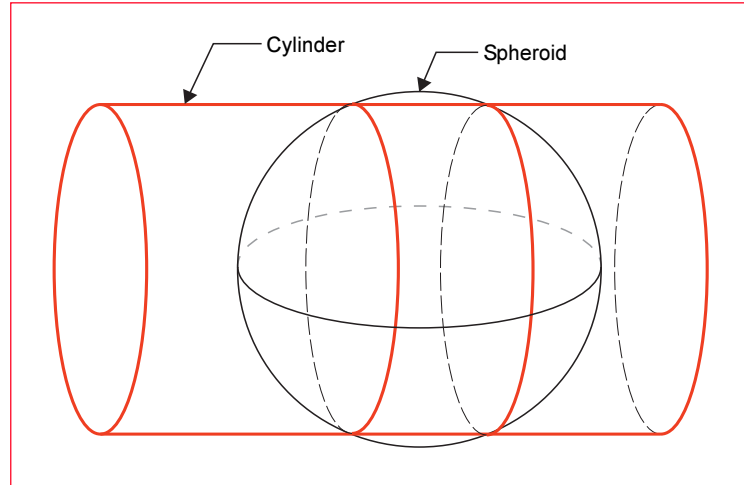

*Transverse Mercator projection*

The **False Easting and False Northing** are defined in order that the origin of the grid projection can be in the lower left hand corner as convention dictates. This does away with the need for negative coordinates.

The **Latitude of Origin** defines the Latitude of the axis of the cylinder. This is normally the equator (in the northern hemisphere).

The **Central Meridian** defines the direction of grid north and the longitude of the centre of the projection.

Scale varies in an east-west direction. As the cylinder is usually smaller than the spheroid, the **Scale on Central Meridian** is too small, is correct on the ellipses of intersection and is then too large at the edges of the projection.

The scale in the north-south direction does not vary. For this reason, the Transverse Mercator projection is most suitable for mapping areas that are long in the north-south direction.

The **Zone Width** defines the portion of the spheroid in an east-west direction to which the projection applies.

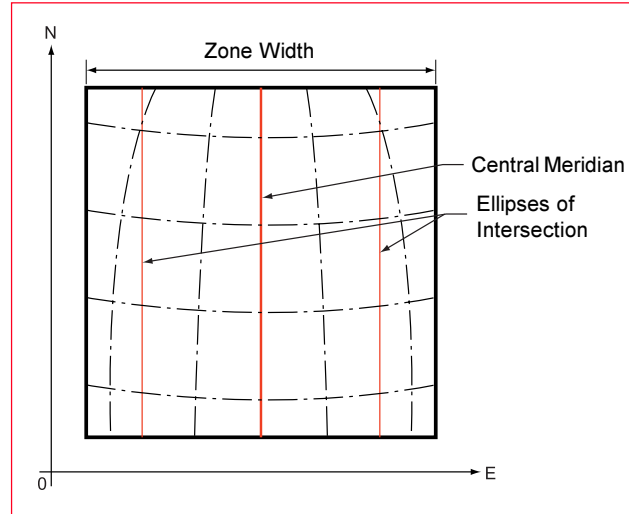

*Features of the Transverse Mercator projection*

### **Universal Transverse Mercator (UTM)**

The UTM projection covers the world between 80°N and 80°S latitude. It is a type of Transverse Mercator projection, with many of the defining parameters held fixed. The UTM is split into zones of 6° longitude with adjacent zones overlapping by 30'. The one defining parameter is the Central Meridian or Zone Number. (When one is defined, the other is implied).

## 4.6.2 The Lambert Projection

The Lambert Projection is also a conformal projection based on a cone that intersects the spheroid. It is ideal for small, circular countries, islands and polar regions.

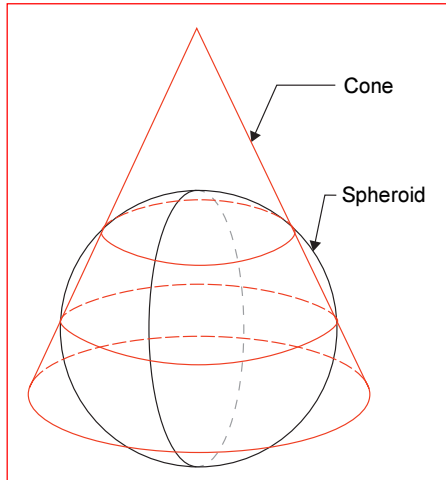

**The Lambert Projection**

The Lambert projection is defined by:

- False Easting and Northing
- Latitude of origin
- Central Meridian

- Latitude of 1st Standard Parallel
- Latitude of 2nd Standard Parallel

The **False Easting and False Northing** are defined in order that the origin of the grid projection can be in the lower left hand corner as convention dictates. This does away with the need for negative coordinates.

The **Latitude of Origin** defines the latitude of the origin of the projection.

The **Central Meridian** defines the direction of grid north and the longitude of the centre of the projection.

The **Latitude of 1st Standard Parallel** defines the latitude at which the cone first cuts the spheroid. This also defines where the

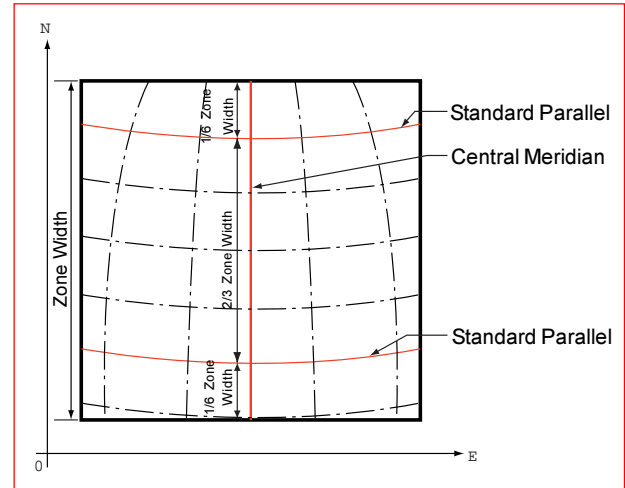

**Features of the Lambert Projection**

influence of scale in the north-south direction is zero.

The **Latitude of 2nd Standard Parallel** defines the second latitude at which the cone cuts the pyramid. The influence of scale will also be zero at this point.

The scale is too small between the standard parallels and too large outside them, being defined by the latitudes of the Standard Parallels at which it is zero. Scale in the east-west direction does not vary.

## 5. Surveying with GPS

Probably even more important to the surveyor or engineer than the theory behind GPS, are the practicalities of the effective use of GPS.

Like any tool, GPS is only as good as its operator. Proper planning and preparation are essential ingredients of a successful survey, as well as an awareness of the capabilities and limitations of GPS.

### Why use GPS?

GPS has numerous advantages over traditional surveying methods:

1. Intervisibility between points is not required.
2. Can be used at any time of the day or night and in any weather.
3. Produces results with very high geodetic accuracy.
4. More work can be accomplished in less time with fewer people.

### Limitations

In order to operate with GPS it is important that the GPS Antenna has a clear view to at least 4 satellites. Sometimes, the satellite signals can be blocked by tall buildings, trees etc. Hence, GPS cannot be used indoors. It is also difficult to use GPS in town centers or woodland.

Due to this limitation, it may prove more cost effective in some survey applications to use an optical total station or to combine use of such an instrument with GPS.

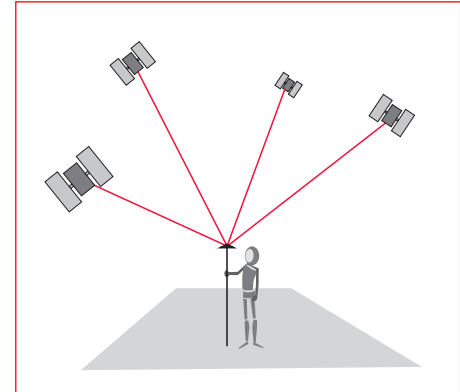

*Clear view to four satellites*

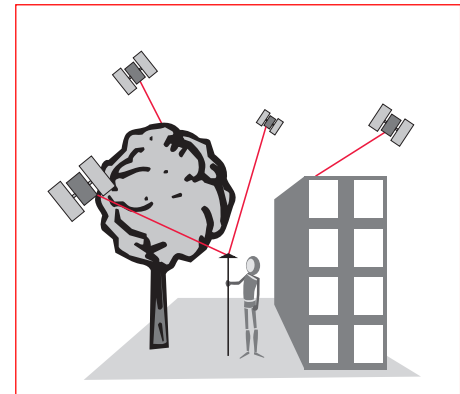

*Large objects can block the GPS signal*

## 5.1 GPS Measuring Techniques

---

There are several measuring techniques that can be used by most GPS Survey Receivers. The surveyor should choose the appropriate technique for the application.

**Static** - Used for long lines, geodetic networks, tectonic plate studies etc. Offers high accuracy over long distances but is comparatively slow.

**Rapid Static** - Used for establishing local control networks, Network densification etc. Offers high accuracy on baselines up to about 20km and is much faster than the Static technique.

**Kinematic** - Used for detail surveys and measuring many points in quick succession. Very efficient way of measuring many points that are close together. However, if there are obstructions to the sky such as bridges, trees, tall buildings etc., and less than 4 satellites are tracked, the equipment must be reinitialized which can take 5-10 minutes.

A processing technique known as On-the-Fly (OTF) has gone a long way to minimise this restriction.

**RTK - Real Time Kinematic** uses a radio data link to transmit satellite data from the Reference to the Rover. This enables coordinates to be calculated and displayed in real time, as the survey is being carried out. Used for similar applications as Kinematic. A very effective way for measuring detail as results are presented as work is carried out. This technique is however reliant upon a radio link, which is subject to interference from other radio sources and also line of sight blockage.

### 5.1.1 Static Surveys

---

This was the first method to be developed for GPS surveying. It can be used for measuring long baselines (usually 20km (16 miles) and over).

One receiver is placed on a point whose coordinates are known accurately in WGS84. This is known as the Reference Receiver. The other receiver is placed on the other end of the baseline and is known as the Rover.

Data is then recorded at both stations simultaneously. It is important that data is being recorded at the same rate at each station. The data collection rate may be typically set to 15, 30 or 60 seconds.

The receivers have to collect data for a certain length of time. This time is influenced by the length of the line, the number of satellites observed and the satellite geometry (dilution of precision or DOP). As a rule of thumb, the observation time is a minimum of 1 hour for a 20km line with 5 satellites and a prevailing GDOP of 8. Longer lines require longer observation times.

Once enough data has been collected, the receivers can be switched off. The Rover can then be moved to the next baseline and measurement can once again commence.

It is very important to introduce redundancy into the network that is being measured. This involves measuring points at least twice and creates safety checks against problems that would otherwise go undetected.

A great increase in productivity can be realized with the addition of an extra Rover receiver. Good coordination is required between the survey crews in order to maximize the potential of having three receivers. An example is given on the next page.

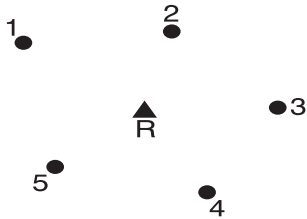

**1**

The network ABCDE has to be measured with three receivers. The coordinates of A are known in WGS84. The receivers are placed on A, B and C. GPS data is recorded for the required length of time.

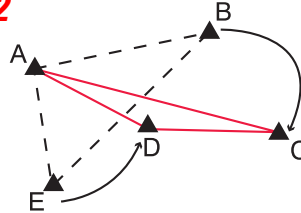
**2**

After the required length of time, the receiver that was at E moves to D and B moves to C. The triangle ACD is measured.

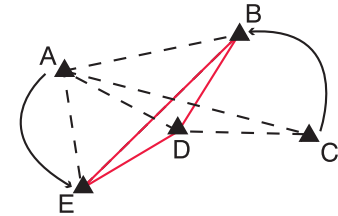
**3**

Then A moves to E and C moves to B. The triangle BDE is measured.

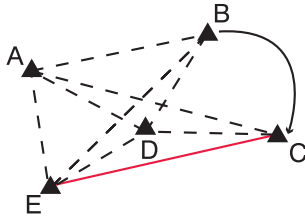
**4**

Finally, B moves back to C and the line EC is measured.

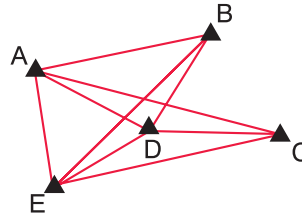
**5**

The end result is the measured network ABCDE. One point is measured three times and every point has been measured at least twice. This provides redundancy. Any gross errors will be highlighted and the offending measurement can be removed.

## 5.1.2 Rapid Static Surveys

---

In Rapid Static surveys, a Reference Point is chosen and one or more Rovers operate with respect to it.

Typically, Rapid Static is used for densifying existing networks, establishing control etc.

When starting work in an area where no GPS surveying has previously taken place, the first task is to observe a number of points, whose coordinates are accurately known in the local system. This will enable a transformation to be calculated and all hence, points measured with GPS in that area can be easily converted into the local system.

As discussed in section 4.5, at least 4 known points on the perimeter of the area of interest should be observed. The transformation calculated will then be valid for the area enclosed by those points.

The Reference Receiver is usually set up at a known point and can be included in the calculations of the transformation parameters. If no known point is available, it can be set up anywhere within the network.

The Rover receiver(s) then visit each of the known points. The length of time that the Rovers must observe for at each point is related to the baseline length from the Reference and the GDOP.

The data is recorded and post-processed back at the office.

Checks should then be carried out to ensure that no gross errors exist in the measurements. This can be done by measuring the points again at a different time of the day.

When working with two or more Rover receivers, an alternative is to ensure that all rovers operate at each occupied point simultaneously. Thus allows data from each station to be used as either Reference or Rover during post-processing and is the most efficient way to work, but also the most difficult to synchronise.

Another way to build in redundancy is to set up two reference stations, and use one rover to occupy the points as shown in the lower example on the next page.

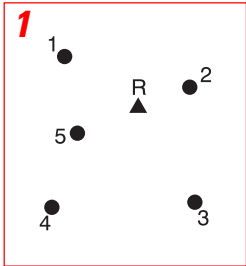

The network 1,2,3,4,5 has to be measured from Reference station R with three GPS receivers.

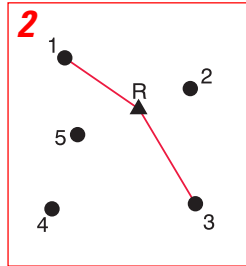

The reference station is set up. One Rover occupies point 1 whilst the other occupies point 3.

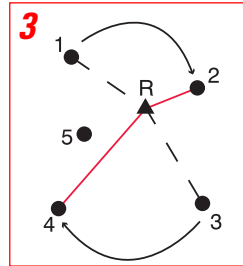

After the required length of time, one Rover moves to point 2 whilst the other moves to point 4.

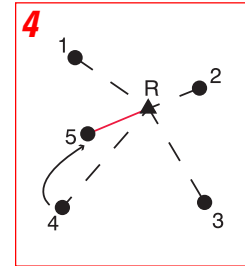

Then, one Rover can return to the office whilst the other measures point 5.

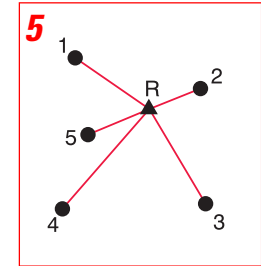

The end result is as above. On a subsequent day, the operation will be repeated in order to check for gross errors.

### Alternatively...

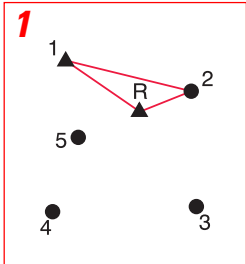

Reference stations are set up at R and point 1. The Rover occupies point 2.

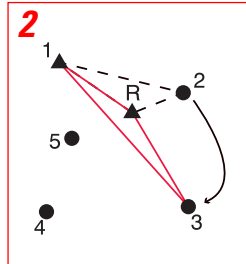

After the required length of time, the Rover moves to point 3.

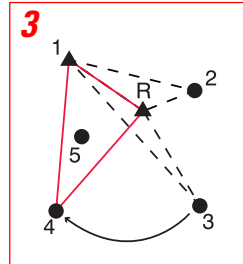

Similarly, the Rover then progresses to point 4...

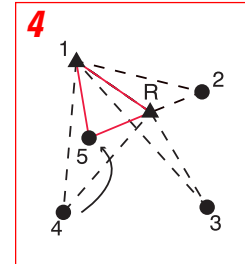

...and then point 5.

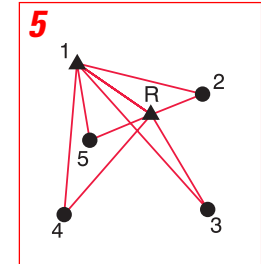

The end result is a measured network with built-in redundancy.

### 5.1.3 Kinematic Surveys

The Kinematic technique is typically used for detail surveying, recording trajectories etc., although with the advent of RTK its popularity is diminishing.

The technique involves a moving Rover whose position can be calculated relative to the Reference.

Firstly, the Rover has to perform what is known as an initialization. This is essentially the same as measuring a Rapid Static point and enables the post-processing software to resolve the ambiguity when back in the office. The Reference and Rover are switched on and remain absolutely stationary for 5-20 minutes, collecting data. (The actual time depends on the baseline length from the Reference and the number of satellites observed).

After this period, the Rover may then move freely. The user can record positions at a predefined recording rate, can record distinct positions, or record a combination of the two. This part of the measurement is commonly called the kinematic chain.

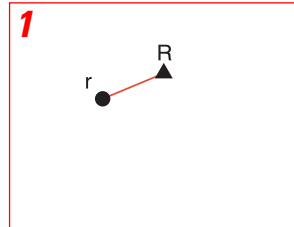

Initialization is performed from the Reference to the Rover.

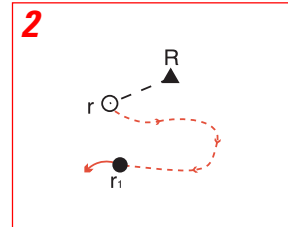

The Rover can then move. Positions can be recorded at a predefined interval...

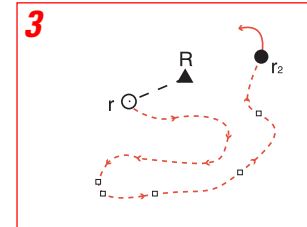

...and also at distinct points if required.

A major point to watch during kinematic surveys is to avoid moving too close to objects that could block the satellite signal from the Rover receiver. If at any time, less than four satellites are tracked by the Rover receiver, you must stop, move into a position where 4 or more satellites are tracked and perform an initialization again before continuing.

#### Kinematic on the Fly

This is a variation of the Kinematic technique and overcomes the requirement of initializing and subsequent re-initialization when the number of observed satellites drops below four.

Kinematic on the Fly is a processing method that is applied to the measurement during post-processing. At the start of measurement, the operator can simply begin walking with the Rover receiver and record data. If they walk under a tree and lose the satellites, upon emerging back into satellite coverage, the system will automatically reinitialize.

## 5.1.4 RTK Surveys

---

RTK stands for Real Time Kinematic. It is a Kinematic on the Fly survey carried out in real time.

The Reference Station has a radio link attached and rebroadcasts the data it receives from the satellites.

The Rover also has a radio link and receives the signal broadcast from the Reference. The Rover also receives satellite data directly from the satellites via its own GPS Antenna. These two sets of data can be processed together at the Rover to resolve the ambiguity and therefore obtain a very accurate position relative to the Reference receiver.

Once the Reference Receiver has been set up and is broadcasting data through the radio link, the Rover Receiver can be activated.

When it is tracking satellites and receiving data from the Reference, it can begin the initialization process. This is similar to the initialization performed in a post-processed kinematic on the fly survey, the main difference being that it is carried out in real-time.

Once the initialization is complete, the ambiguities are resolved and the Rover can record point and coordinate data. At this time, baseline accuracies will be in the 1 - 5cm range.

It is important to maintain contact with the Reference Receiver, otherwise the Rover may lose the ambiguity. This results in a far less accurate position being calculated.

Additionally, problems may be encountered when surveying close to obstructions such as tall buildings, trees etc. as the satellite signal may be blocked.

RTK is quickly becoming the most common method of carrying out high precision, high accuracy GPS surveys in small areas and can be used for similar applications as a conventional total station. This includes detail surveying, stakeout, COGO applications etc.

### The Radio Link

Most RTK GPS systems make use of small UHF radio modems. Radio communication is the part of the RTK system that most people experience difficulty with. It is worth considering the following influencing factors when trying to optimize radio performance:

1. Power of the transmitting radio. Generally speaking, the more power, the better the performance. However, most countries legally restrict output power to 0.5 - 2W.
2. Height of transmitter antenna. Radio communication can be affected by line of sight. The higher up you can position the antenna, the less likely you are to get line of sight problems. It will also increase the overall range of radio communication. The same also applies to the receiving antenna.

Other influencing factors affecting performance include the length of the cable to radio antenna (longer cables mean higher losses) and the type of radio antenna used.

## 5.2 Pre-survey preparation

Before heading out into the field, the surveyor needs to prepare for the survey. Items that must be considered are:

1. Radio Licences
2. Power - charged batteries
3. Spare cables
4. Communication between survey parties
5. Coordinates of Reference Station
6. Memory cards - Do you have enough spare memory?
7. Observation schedule. First objective should be to get enough information for determination of Transformation Parameters, then aim for redundancy of observations.

## 5.3 Tips during operation

For Static and Rapid Static surveys, always fill out a record sheet for each point you survey. An example is given on the next page.

With Static and Rapid Static surveys, it is vital that the antenna height is measured correctly. This is one of the most common mistakes when carrying out a GPS survey. Measure the height at the beginning and end of occupation. With Kinematic and RTK Surveys, the antenna is usually mounted on a pole which has a constant height.

During Static and Rapid Static surveys, the GPS antenna has to be kept totally still. This also applies to the Rapid Static initialization of Kinematic surveys (but not to Kinematic on the Fly or RTK surveys). Any movement or vibration in the antenna can adversely affect the result.

## ***Field Sheet***

Point Id	_____	Date	_____	Notes	_____
Sensor Serial No	_____	Operator	_____		_____
Operation Type	_____				
Antenna Type	_____				
Height Reading	_____				
Start Time	_____				
Stop Time	_____				
No. of Epochs	_____				
No. of Satellites	_____				
GDOP	_____				

## Almanac

Library of coarse satellite orbital data used to calculate satellite position, rise time, elevation, and azimuth.

## Ambiguity

The unknown integer number of cycles of the reconstructed carrier phase contained in an unbroken set of measurements from a single satellite pass at a single receiver.

## Anti-spoofing (A-S)

Encrypting the P-code (to form the Y-code).

## Atmospheric propagation delay

Time delay affecting satellite signals due to tropospheric layers of the earth's atmosphere.

## Azimuth

A horizontal angle measured clockwise from a direction (such as North).

## Bandwidth

A measure of the width of the spectrum of a signal (frequency domain representation of a signal) expressed in Hertz.

## Baseline

The length of the three-dimensional vector between a pair of stations for which simultaneous GPS data has been collected and processed with differential techniques.

## Bearing

Term used in navigation to describe the angle between a reference direction (e.g., geographic north, magnetic north, grid north) and the trajectory.

## Beat frequency

Either of the two additional frequencies obtained when signals of two frequencies are mixed. The beat frequencies are equal to the sum or difference of the original frequencies, respectively.

## Binary biphase modulation

Phase changes of either  $0^\circ$  or  $180^\circ$  (to represent binary 0 or 1, respectively) on a constant frequency carrier. These can be modelled by

$$y = A \cos (wt + p),$$

where the amplitude function  $A$  is a sequence of +1 and -1 values (to represent  $0^\circ$  and  $180^\circ$  phase changes respectively). GPS signals are biphase modulated.



---

### **C/A code**

The Coarse/Acquisition GPS code modulated on the GPS L1 signal. This code is a sequence of 1023 pseudorandom binary biphasic modulations on the GPS carrier at a chipping rate of 1.023 MHz, thus having a code repetition period of one millisecond.

### **Cartesian Coordinates**

The coordinates of a point in space given in three mutually perpendicular dimensions (x, y, z) from the origin.

### **Carrier**

A radio wave having at least one characteristic (e.g., frequency, amplitude, phase) which may be varied from a known reference value by modulation.

### **Carrier beat phase**

The phase of the signal which remains when the incoming Doppler-shifted satellite carrier signal is beat (the difference frequency signal is generated)

with the nominally constant reference frequency generated in the receiver.

### **Carrier frequency**

The frequency of the unmodulated fundamental output of a radio transmitter. The GPS L1 carrier frequency is 1575.42 MHz, the GPS L2 carrier frequency is 1227.60 MHz.

### **Chip**

The time interval of either a zero or a one in a binary pulse code

### **Chip rate**

Number of chips per second (e.g., C/A code :  $1.023 \times 10^6$  cps)

### **Clock offset**

Constant difference in the time reading of two clocks.

### **Code**

A system used for communication in which arbitrarily chosen strings of zeros and ones are assigned definite meanings.

### **Compacted data**

Raw data compacted over a specified time interval (compaction time) into one single observable (measurement) for recording.

### **Conformal Projection**

A map projection that preserves angles on the ellipsoid after they have been mapped onto the plane.

### **Control segment**

Ground-based GPS System equipment operated by the U.S. Government that tracks the satellite signals, determines the orbits of the satellites, and transmits orbit definitions to the memories of the satellites.

---

### **Cutoff angle**

The minimum elevation angle below which no more GPS satellites are tracked by the sensor.

### **Cycle slip**

A discontinuity of an integer number of cycles in the measured carrier beat phase resulting from a temporary loss of lock of a GPS satellite signal.

### **Data message**

A message included in the GPS signal that reports the satellite's location, clock corrections, and health. Included is rough information on the status of other satellites in the constellation.

### **DGPS**

Differential GPS. The term commonly used for a GPS system that utilizes differential code corrections to achieve an enhanced positioning accuracy of around 0.5 - 5m.

### **Deflection of the vertical**

The angle between the normal to the ellipsoid and the vertical (true plumb line). It is usually resolved into a component in the meridian and a component perpendicular to the meridian.

### **Delay lock**

The technique whereby the received code (generated by the satellite clock) is compared with the internal code (generated by the receiver clock) and the latter shifted in time until the two codes match.

### **Differenced measurements**

GPS measurements can be differenced across receivers, across satellites and across time. Although many combinations are possible, the present convention for GPS phase measurement differencing is to perform the differences in the above order: first across receivers, second across satellites and third across time.

A single difference measurement (across receivers) is the instantaneous difference in phase of a received signal, measured by two receivers simultaneously observing one satellite.

A double difference measurement (across receivers and satellites) is obtained by differencing the single difference for one satellite with respect to the corresponding single difference for a chosen reference satellite.

A triple difference measurement (across receivers, satellites and time) is the difference between a double difference at one epoch of time and the same double difference at another epoch of time.

### **Differential positioning**

Determination of relative coordinates between two or more receivers which are simultaneously tracking the same GPS signals.

---

### **Dilution of precision (DOP)**

A description of the purely geometrical contribution to the uncertainty in a position fix. The DOP factor indicates the geometrical strength of the satellite constellation at the time of measurement. Standard terms in the case of GPS are

GDOP three position coordinates plus clock offset

PDOP three coordinates

HDOP two horizontal coordinates

VDOP height only

TDOP clock offset only

HTDOP horizontal position and time

### **Doppler shift**

The apparent change in frequency of a received signal due to the rate of change of the range between the transmitter and receiver.

### **Eccentricity**

The ratio of the distance from the centre of an ellipse to its focus to the semimajor axis.

$$e = (1 - b^2/a^2)^{1/2}$$

where a and b are the semimajor and semiminor axis of the ellipse, respectively.

### **Elevation**

Height above the Geoid. See Orthometric height.

### **Ellipsoid**

In geodesy, unless otherwise specified, a mathematical figure formed by revolving an ellipse about its minor axis (sometimes also referred to as spheroid). Two quantities define an ellipsoid; these are usually given as the length of the semimajor axis a and the flattening f.

### **Ellipsoid height**

The vertical distance of a point above the ellipsoid.

### **Ephemeris**

A list of positions or locations of a celestial object as a function of time.

### **Ephemeris error**

Difference between the actual satellite location and the location predicted by the satellite orbital data (ephemerides).

### **Epoch**

A particular fixed instant of time used as a reference point on a time scale.

### **Equipotential Surface**

A mathematically defined surface where the gravitational potential is the same at any point on that surface. An example of such a surface is the geoid.

---

## Flattening

Relating to Ellipsoids.

$$f = (a-b)/a = 1-(1-e^2)^{1/2}$$

where a ... semimajor axis

b ... semiminor axis

e ... eccentricity

## Fundamental frequency

The fundamental frequency used in GPS is 10.23 MHz. The carrier frequencies L1 and L2 are integer multiples of the fundamental frequency.

$$L1 = 154F = 1575.42 \text{ MHz}$$

$$L2 = 120F = 1227.60 \text{ MHz}$$

## GDOP

Geometric dilution of precision

—> *Dilution of precision*

## Geocentric

Relating to the centre of the earth.

## Geodesy

The study of the earth's size and shape

## Geodetic Coordinates

Coordinates defining a point with reference to an ellipsoid. Geodetic Coordinates are either defined using latitude, longitude and ellipsoidal height or using Cartesian coordinates.

## Geodetic Datum

A mathematical model designed to best fit part or all of the geoid. It is defined by an ellipsoid and the relationship between the ellipsoid and a point on the topographic surface established as the origin of datum. This relationship can be defined by six quantities, generally (but not necessarily) the geodetic latitude, longitude, and the height of the origin, the two components of the

deflection of the vertical at the origin, and the geodetic azimuth of a line from the origin to some other point.

## Geoid

The particular equipotential surface which coincides with mean sea level, and which may be imagined to extend through the continents. This surface is everywhere perpendicular to the direction of the force of gravity.

## Geoidal Height

See Geoid separation

## Geoid separation

The distance from the surface of the reference ellipsoid to the geoid measured outward along the normal to the ellipsoid.

## GPS

Global Positioning System

---

### GPS time

A continuous time system based on the Coordinated Universal Time (UTC) from 6th January 1980.

### Greenwich mean time (GMT)

The mean solar time of the meridian of Greenwich. Used as the prime basis of standard time throughout the world.

### Great circle course

Term used in navigation. Shortest connection between two points.

### Graticule

A plane grid representing the lines of Latitude and Longitude of an ellipsoid.

### Gravitational constant

The proportionality constant in Newton's Law of gravitation.

$$G = 6.672 \times 10^{-11} \text{ m}^3\text{s}^{-2}\text{kg}^{-1}$$

### Inclination

The angle between the orbital plane of an object and some reference plane (e.g., equatorial plane).

### Integer bias term

See Ambiguity

### Ionospheric Delay

A wave propagating through the ionosphere (which is a non-homogeneous and dispersive medium) experiences delay. Phase delay depends on electron content and affects carrier signals. Group delay depends on dispersion in the ionosphere as well, and affects signal modulation (codes). The phase and group delay are of the same magnitude but opposite sign.

### Kinematic positioning

Determination of a time series of sets of coordinates for a moving receiver, each set of coordinates being determined from a single data sample, and usually computed in real time.

### Keplerian orbital elements

Allow description of any astronomical orbit:

a: semimajor axis

e: eccentricity

w: argument of perigee

W: right ascension of ascend ing node

i: inclination

n: true anomaly

### Lambert Projection

A conformal conic map projection that projects an ellipsoid onto a plane surface by placing a cone over the sphere.

### Latitude

The angle between the ellipsoidal normal and the equatorial plane. Latitude is zero on the equator and 90° at the poles.

---

## **L-band**

The radio frequency band extending from 390 MHz to 1550 MHz. The frequencies of the L1 and L2 carriers transmitted by GPS satellites lie within this L-band.

## **Least squares estimation**

The process of estimating unknown parameters by minimizing the sum of the squares of measurement residuals.

## **Local Ellipsoid**

An Ellipsoid that has been defined for and fits a specific portion of the earth. Local ellipsoids usually fit single or groups of countries.

## **Local Time**

Local time equals to GMT time + time zone.

## **Longitude**

Longitude is the angle between the meridian ellipse which passes through Greenwich and the meridian ellipse containing the point in question. Thus, Latitude is 0° at Greenwich and then measured either eastward through 360° or eastward 180° and westward 180°.

## **Meridian**

An imaginary line joining north to south pole and passing through the equator at 90°.

## **Multipath error**

A positioning error resulting from interference between radio waves which have travelled between the transmitter and the receiver by two paths of different electrical lengths.

## **NAVSTAR**

Acronym for Navigation System with Time and Ranging, the original name for GPS.

## **NMEA**

National Marine Electronics Association. Defined a standard (NMEA 0183) to enable marine electronics instruments, communication and navigation equipment to communicate. This standard is used to get time and position data out of GPS instruments in many applications.

## **Observing Session**

A period of time over which GPS data is collected simultaneously by two or more receivers.

## **Orthometric height**

The distance of a point above the geoid measured along the plumb line through the point (height above mean sea level). See also Elevation.

---

## **P-code**

The Precise GPS code - a very long (about  $10^{14}$  bit) sequence of pseudorandom binary biphasic modulations on the GPS carrier at a chipping rate of 10.23 MHz which does not repeat itself for about 267 days. Each one-week segment of the P-code is unique to one GPS satellite, and is reset each week. Access to the P-code will be restricted by the U.S. Government to authorized users only.

## **PDOP**

Position dilution of precision.

see Dilution of Precision

## **Phase observable**

See Reconstructed Carrier Phase

## **Point Positioning**

The independent reduction of observations made by a particular receiver using the pseudorange information broadcast from the satellites.

## **Post processing**

The process of computing positions in non-real-time, using data previously collected by GPS receivers.

## **Precise positioning service (PPS)**

The highest level of point positioning accuracy provided by GPS. It is based on the dual-frequency P - code.

## **Propagation delay**

See Atmospheric propagation delay, and Ionospheric delay

## **Pseudolite**

The ground-based differential GPS station which transmits a signal with a structure similar to that of an actual GPS satellite.

## **Pseudorandom noise (PRN) code**

Any group of binary sequences that

appear to be randomly distributed like noise, but which can be exactly distributed. The most important property of PRN codes is that the sequence has a minimum autocorrelation value, except at zero lag.

## **Pseudorange**

A measure of the apparent signal propagation time from the satellite to the receiver antenna, scaled into distance by the speed of light. The apparent propagation time is the difference between the time of signal reception (measured in the receiver time frame) and the time of emission (measured in the satellite time frame). Pseudorange differs from the actual range by the influence of satellite and user clock.

## **Range**

Term used in Navigation for the length of the trajectory between two points. The trajectory is normally the great circle or the rhumb line.

---

### **Rapid static survey**

Term used in connection with the GPS System for static survey with short observation times. This type of survey is made possible by the fast ambiguity approach that is resident in the SKI software.

### **Raw data**

Original GPS data taken and recorded by a receiver.

### **Receiver channel**

The radio frequency and digital hardware and the software in a GPS receiver, required to track the signal from one GPS satellite at one of the two GPS carrier frequencies.

### **Reconstructed carrier phase**

The difference between the phase of the incoming Doppler-shifted GPS carrier and the phase of a nominally-constant reference frequency generated in the receiver.

### **Relative positioning**

See Differential positioning

### **Rhumb line**

Term used in navigation. Trajectory between two points with constant bearing.

### **RINEX**

Receiver INdependent EXchange format. A set of standard definitions and formats to promote the free exchange of GPS data

### **RTCM**

Radio Technical Commission for Maritime services. Commission set up to define a differential data link to relay GPS messages from a monitor station to a field user.

### **RTK**

Real Time Kinematic. A term used to describe the procedure of resolving the phase ambiguity at the GPS receiver so that the need for post-processing is removed.

### **Satellite Constellation**

The arrangement in space of the complete set of satellites of a system like GPS.

### **Satellite Configuration**

The state of the satellite constellation at a specific time, relative to a specific user or set of users.

### **Selective availability (SA)**

Degradation of point positioning accuracy for civil users by the U.S. Department of Defense. SA is produced by either clock dithering or orbit degradation.



---

**Sidereal day**

Time interval between two successive upper transits of the vernal equinox.

**Site**

A location where a receiver has been setup to determine coordinates.

**Space segment**

The part of the whole GPS system that is in space, i.e. the satellites.

**Solar day**

Time interval between two successive upper transits of the Sun.

**Squared reception mode**

A method used for tracking GPS L2 signals which doubles the carrier frequency and does not use the P-code.

**Squaring-type channel**

A GPS receiver channel which multiplies the received signal by itself to obtain a second harmonic of the carrier which does not contain the code modulation.

**Standard positioning service (SPS)**

Level of point positioning accuracy provided by GPS based on the single-frequency C/A - code.

**Static Survey**

The expression static survey is used in connection with GPS for all non-kinematic survey applications. This includes the following operation modes:

- Static survey
- Rapid static survey

**Stop & Go Survey**

The term Stop & Go survey is used in connection with GPS for a special kind of kinematic survey. After initialization (determination of ambiguities) on the first site, the roving receiver has to be moved between the other sites without losing lock to the satellite signal. Only a few epochs are then necessary on these sites to get a solution with survey accuracy. Once loss of lock occurred, a new initialization has to be done.

**Time Zone**

Time zone = Local Time - Greenwich Mean Time (GMT). Note that Greenwich Mean Time is approximately equal to GPS time.

**Topography**

The form of the land of a particular region.

---

## Transformation

The process of transforming coordinates from one system to another.

## Transit

The predecessor to GPS. A satellite navigation system that was in service from 1967 to 1996.

## Transverse Mercator Projection

A conformal cylindrical map projection which may be visualized as a cylinder wrapped around the earth.

## Translocation

The method of using simultaneous data from separate stations to determine the relative position of one station with respect to another station. See differential positioning.

## Universal time

Local solar mean time at Greenwich Meridian

UT Abbreviation for universal time

UT0 UT as deduced directly from observation of stars

UT1 UT0 corrected for polar motion

UT2 UT1 corrected for seasonal variations in the Earth's rotation rate

UTC Universal Time Coordinated; uniform atomic time system kept very close to UT2 by offsets.

## User equivalent range error (UERE)

The contribution to the range measurement error from an individual error source, converted into range units, assuming that error source is uncorrelated with all other error sources.

## User segment

The part of the GPS system that includes the receivers of GPS signals.

## UTM

Universal Transverse Mercator Projection. A form of Transverse Mercator projection. The projection has different zones, each 6° wide with a central scale factor of 0.996. Which zone is used depends upon your location on the earth.

## Y-code

An encrypted version of the P-code that is transmitted by a GPS satellite when in the anti-spoofing mode.

## WGS 84

World Geodetic System 1984. The system on which all GPS measurements and results are based.

## Zenith angle

Vertical angle with 0° on the horizon and 90° directly overhead.

### **GPS Theory and Practice -**

B. Hofmann-Wellenhof, H. Lichtenegger and J. Collins.  
ISBN 3-211-82839-7 Springer Verlag.

### **GPS Satellite Surveying -**

Alfred Leick.  
ISBN 0471306266 John Wiley and Sons.

### **Satellite Geodesy: Foundations, Methods and Applications -**

Gunter Seeber.  
ISBN 3110127539 Walter De Gruyter.

### **Understanding GPS: Principles and Applications**

Elliot D. Kaplan (Ed.).  
ISBN 0890067937 Artech House.

### **The Global Positioning System: Theory and Applications**

Bradford W. Parkinson and James J. Spilker (Eds.).  
ISBN 9997863348 American Institute of Aeronautics and Astronautics.

## A

Almanac [48](#)  
Ambiguity [24](#), [45](#), [48](#)  
Ambiguity Resolution [22](#), [24](#)  
Anti-Spoofing (A-S). See Error Sources  
Atmospheric propagation delay [48](#)  
Azimuth [48](#)

## B

Bandwidth [48](#)  
Baseline [48](#)  
Bearing [48](#)  
Beat frequency [48](#)  
Binary biphasic modulation [48](#)

## C

C/A code [7](#), [13](#), [18](#), [22](#), [49](#)  
Carrier [49](#)  
Carrier beat phase [49](#)  
Carrier phase [22](#), [23](#), [49](#)  
Cartesian coordinates [28](#), [49](#)  
Central Meridian [36](#), [37](#)  
Chip [49](#)  
Chip rate [49](#)  
Choke-Ring Antenna [16](#)  
Clock (Satellite and Receiver) [16](#)  
Clock offset [49](#)  
Code [49](#)

Compacted data [49](#)  
Conformal Projection [49](#)  
Control segment [8](#), [49](#)  
Coordinate system [28](#)  
    Cartesian [28](#), [49](#)  
    GPS [28](#)  
    Local [29](#)  
Coordinate transformation [31](#)  
    Helmert [32](#)  
    Interpolation [33](#)  
    One Step [33](#)  
    Stepwise [33](#)  
Cutoff angle [50](#)  
Cycle slip [50](#)

## D

Data message [50](#)  
Deflection of the vertical [50](#)  
Delay lock [50](#)  
DGPS [10](#), [19](#), [20](#), [50](#)  
Differenced measurements [50](#)  
Differential positioning [50](#)  
Differential phase [22](#)  
Dilution of precision (DOP) [51](#)  
    GDOP [17](#), [51](#), [52](#)  
    HDOP [17](#), [51](#)  
    HTDOP [51](#)  
    PDOP [17](#), [51](#), [55](#)  
    TDOP [51](#)

VDOP [17](#), [51](#)  
Distance to satellite [13](#)  
Doppler shift [51](#)  
Double difference [23](#), [50](#)

## E

Eccentricity [51](#)  
Elevation [51](#)  
Ellipsoid [28](#), [51](#)  
Ellipsoid height [30](#), [51](#)  
Ephemeris [51](#)  
Epoch [51](#)  
Equipotential Surface [51](#)  
Error Sources [14](#)  
    Anti-Spoofing (A-S) [18](#), [48](#)  
    Dilution of Precision [17](#), [51](#)  
    Multipath [16](#), [54](#)  
    Satellite and Receiver clock [16](#)  
    Selective Availability (S/A) [18](#), [56](#)  
    Water Vapour [15](#)

## F

False Easting [36](#), [37](#)  
False Northing [36](#), [37](#)  
Flattening [52](#)  
Fundamental frequency [52](#)

## **G**

GDOP. See [Dilution of precision \(DOP\)](#)  
Geocentric [52](#)  
Geodesy [52](#)  
Geodetic Datum [52](#)  
Geoid [52](#)  
Geoid separation [30](#), [33](#), [52](#)  
GPS [52](#)  
GPS time [53](#)  
Graticule [53](#)  
Gravitational constant [53](#)  
Great circle cours [53](#)  
Greenwich mean time (GMT) [53](#)

## **H**

Helmert Transformation [32](#)

## **I**

Inclination [53](#)  
Integer bias term [53](#)  
Ionospheric Delay [14](#), [53](#)

## **K**

Keplerian orbital elements [53](#)  
Kinematic [39](#), [44](#), [53](#)  
Kinematic On the Fly (OTF) [39](#), [44](#)

## **L**

L-band [54](#)  
Lambert Projection [53](#)  
Latitude [28](#), [53](#)  
Latitude of Origin [36](#), [37](#)  
Least squares estimation [54](#)  
Longitude [28](#), [54](#)

## **M**

Map projection [34](#)  
    Lambert [37](#)  
    Transverse Mercator [35](#)  
    Universal Transverse Mercator [36](#)  
Measuring techniques (GPS) [39](#)  
    Kinematic [39](#), [44](#)  
    Kinematic On the Fly (OTF) [39](#), [44](#)  
    Rapid Static [39](#), [42](#)  
    Real Time Kinematic (RTK) [39](#), [45](#), [56](#)  
    Static [39](#), [40](#)  
Meridian [54](#)  
Multipath error [54](#)

## **N**

NAVSTAR [5](#), [54](#)  
NMEA [54](#)

## **O**

Orthometric height [30](#), [54](#)

## **P**

P-code [55](#)  
Phase observable [55](#)  
Point Positioning [55](#)  
Post processing [55](#)  
Precise positioning service (PPS) [55](#)  
Projection. See [Map projection](#)  
Propagation delay [55](#)  
Pseudolite [55](#)  
Pseudorandom noise (PRN) code [55](#)  
Pseudorange [55](#)

## **R**

Radio link [45](#)  
Range [55](#)  
Rapid Static [39](#), [42](#)  
Rapid static survey [56](#)  
Raw data [56](#)  
Real Time Kinematic (RTK) [39](#), [45](#), [56](#)  
Receiver channel [56](#)  
Reconstructed carrier phase [56](#)  
Reference Receiver [20](#)  
Relative positioning [56](#)  
Rhumb line [56](#)  
RINEX [56](#)

---

Rover receiver [20](#)

RTCM [21](#), [56](#)

RTK [39](#), [45](#), [56](#)

## S

Satellite Configuration [56](#)

Satellite Constellation [56](#)

Selective Availability (S/A). See [Error](#)

### Sources

Sidereal day [57](#)

Site [57](#)

Solar day [57](#)

Space segment [57](#)

Squared reception mode [57](#)

Squaring-type channel [57](#)

Standard Parallel [37](#)

Standard positioning service (SPS) [57](#)

Static [39](#), [40](#)

Static Survey [57](#)

Stop & Go Survey [57](#)

## T

Time Zone [57](#)

Topography [57](#)

Transformation [31](#), [58](#)

Helmert transformation [32](#)

Interpolation approach [33](#)

One Step approach [33](#)

Stepwise approach [33](#)

Transit [58](#)

Translocation [58](#)

Transverse Mercator Projection [58](#)

## U

Universal time [58](#)

User equivalent range error (UERE) [58](#)

User segment [58](#)

UTM [58](#)

## W

Water Vapour. See [Error Sources](#)

WGS 84 [58](#)

## Y

Y-code [58](#)

## Z

Zenith angle [58](#)

Zone Width [36](#)



**Leica Geosystems AG, Heerbrugg, Switzerland, has been certified as being equipped with a quality system which meets the International Standards of Quality Management and Quality Systems (ISO standard 9001) and Environmental Management Systems (ISO standard 14001).**



**Total Quality Management-  
Our commitment to total customer  
satisfaction**

*Ask your local Leica agent for more  
information about our TQM program*

713282-1.0.0en

Printed in Switzerland - Copyright Leica  
Geosystems AG, Heerbrugg, Switzerland 1999

**To get more information on Leica GPS  
products visit our homepage:**

**[www.leica-geosystems.com](http://www.leica-geosystems.com)**

**or contact us directly:**

The Leica logo is the word 'Leica' written in a red, cursive script font with a thin red underline.

*Leica Geosystems AG  
Heinrich-Wild-Strasse  
CH-9435 Heerbrugg  
(Switzerland)*

*Phone +41 71 727 31 31  
Fax +41 71 727 47 02*

*[LSGMASTER@leica-geosystems.com](mailto:LSGMASTER@leica-geosystems.com)*

*Leica Geosystems Inc.  
3155 Medlock Bridge Road  
Norcross, GA 30071  
(USA)*

*Phone +1 770 447 6361  
Fax +1 770 447 0710*

*[Carson.Kennedy@leica-geosystems.com](mailto:Carson.Kennedy@leica-geosystems.com)*